

A Study on Vehicle Differential system

¹Chandrakant Singh, ²Lalit Kumar, ³Bhumesh kumar dewangan ⁴Prakash kumar sen, ⁵shailendra kumar bohidar

¹²³Student, Bachelor of engg. Mechanical Engineering

⁴⁵Faculty, Mechanical Engineering Department

Kirodimal institute of technology raigarh, Chhattisgarh, INDIA

chandrakant5233@gmail.com, lalit.sidar341994@gmail.com, bhumeshdewangan5@gmail.com

Abstract: In light commercial vehicles and other wheeled vehicle, an open differential is a device that allows each driven wheel to rotate in different speeds during a curve or in limited grip conditions. When one of the wheels loses the grip the differential will direct all the torque available to the wheel that is spinning making the vehicle get stuck. The automobile industry is always looking for opportunities in terms of weight and size reduction. This new concept is more compact, lighter, quieter, more efficient and with higher performance. In automobile and other wheeled vehicles, the differential allows the outer drive wheel to rotate faster than the inner drive wheel during a turn. During ordinary conditions, when the vehicle is driven down straight road, or if the difference between speeds of the two(rear) wheels is below a specified limit, no signal will be generated by the electronic circuit. This helps the vehicle negotiate the turns with better traction control as differential action is unaltered. But if the difference between speeds is beyond a specified limit, the signal will be generated by the electronic circuit which will actuate the pneumatic circuit.

Keywords: Differential, Differential speed, traction.

1. Introduction

First of all description of differential, differential is an arrangement of gears in an epicyclic train permitting the rotation of two shaft at different speeds, used on the rear axle of automotive vehicles to allow different rates of wheel rotation on curve. The epicyclic gear mounted in the driving wheel to rotate faster than the other. the differential gear a bevel gear permits rotation of two shaft at different speeds; used on the rear axle. The differential is the works both drive axles at the same time, but lets them rotate at different speeds so that the car can make turns. When a car makes a turn, the outer wheel has to turn faster than the inner wheel, due to the difference in the length of the paths they take. The differential is located between the two wheels, and is attached to each wheel by a half-shaft rotated through a bevel gear. Four wheel drive cars have a separate differential for each pair of wheels. The problem with an automotive differential is that if one wheel is held stationary; the counterpart wheel turns at twice its normal speed. This can when be problematic when one wheel does not have enough traction, such as when it is in snow or mud.

The above problem solution is to have differential locking system which can provide engaged or disengaged either manually or automatically. It is a sensor based system can be developed that will sense the difference in speed or stalling of one wheel to lock the differential so that both wheels have same traction. Also the problem solved by electrically controlled mechanical system, which when locked allows no difference in speed between the two wheels on the axel. In dry conditions, the amount of torque applied the wheels is

limited by engine, in low traction situation, such as when driving on ice, the amount of torque is limits to greatest condition. So even thought a car may be produce more torque to the ground. When one tire encounters slippery spot on the road, it losses traction, resistance to rotation drops, and the

wheels begin to spin.

The wheel with good traction is longer drive. If vehicle is stationary this condition, only the wheel over slippery spot rotates. Automatic mechanical lockers do allow for some differentiation under certain conditions, while a selectable locker typically couples both axels with a selected locker [1].

2. Proposed of differential locking system

The differential allows the outer wheel to rotate faster than the inner drive wheel to during a turn. This is necessary when the vehicle turns, making the wheel that is traveling around the outside of the turning curve roll farther and faster than the other. The average of the rotational speed of the two driving wheels equals the input rotational speed of the drive shaft.

An increase in the speed of one wheel is balanced by a decrease in the speed of the other. An automatic differential locking system vehicle having steerable front and rear wheels [2]. Which selecting a steer mode of vehicle, and actuator for operating a differential locking mechanism.

It is improve traction which can be applied by the wheels of vehicle, and automatically engages a locking mechanism [3].

The differential consist of one input, the drive shaft, and two outputs which are the two drive wheels, however the rotation of

the drive wheels are coupled by their connection to the roadway. The sectional view of differential system is containing of many part which is transmit power by many steps:-

- **Pinion drive gear:** transfer power from the drive shaft to the ring gear.
- **Ring gear:** power transfer to differential case assembly.
- **Spider gears:** Both wheel turn independently when turning.
- **Differential case assembly:** Hold the gear and drive the axel.
- **Rear drive axel:** Transfer torque from differential assembly to the drive wheels.
- **Rear axle bearings:** It is fitted between the axels and inside of the axel housing.
- **Axel housing:** It is support the parts of rear axle assembly.

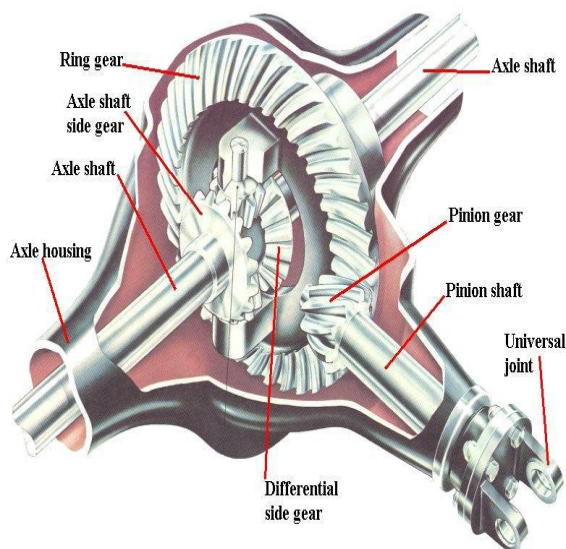

Figure- cross sectional of differential system.[4]

3. Working and construction of differential:-

The working principle of a differential gear assembly can be explained simplified construction. Beside ‘bevel pinion’ and the ‘crown wheel(gear)’, it show an assembly consisting of a ‘cage’, two ‘sun- gear’, ‘two planet pinions ’and a cross pin or spides. The cage is attached to the crown wheel and corner a cross pin the ‘the sun gear ’are always in mesh with the ‘planet pinion’. The half shaft is splined to allow small movement in ‘sun gear’. The outer ends of half shafts are connected to the wheel hub. The crown wheel rotates freely on the bush mounted over one of the half shafts.

The working of the differential assembly may be in the following two cases of vehicle motion:-

- I. When vehicle going straight.
- II. When vehicle is taking a turn.

When vehicle is going straight: in this case, the cage and the epicyclical gear rotates as a single units and the differential units helps the two half shaft to revolve at equal speeds.

When vehicle is taking turn: in this case, the speed of ‘outer wheel’ has to be speeded up as compare to ‘inner wheel’ and inner wheel must be slowed down. Turning of one sun gear will cause the other to rotate in the opposite direction.

• Torque and speed

We can observe that with decrease in speed of output wheel shaft torque is increasing. This is inversely proportional. Hence the sensor sense the reduction in the speed, the locking differential provides same torque on both wheel shafts.

• Power v/s Speed:

With increasing speed, power also increases up to certain limits then there will be same output power that power is known as rated power.

• Efficiency v/s Speed:

Increasing efficiency up to limit with speed further increase in speed will not effect as power Generated will be constant [5].

Cost comparison table

EXISTING SYSTEM	PROPOSED SYSTEM
1.LIMITED SLIP DIFFRENETIAL(LSD)	1.OPEN DIFFERENTIAL : Rs 20,000/-
* TRD LSD : 60,000/-	2.ELECTRONIC CIRCUIT : Rs 1000/-
* QUALIF LSD: 70,000/-	3. SPEED SENSOR : Rs 7500/-
	4. CHEAK VALVE :Rs 1000/-
	5. SOLENITE VALVE : Rs 1000/-

The above table that this system ensures a reduction of more than 50% in the investment as compared to available cost. The differential is found on all modern cars and trucks, and also in many wheel drive vehicles. These wheel drive vehicles need a differential between each set of drive wheels, and they need one between the front and the back wheels as well, because the front wheels travel a different distance through a turn than the rear wheels.

4. Mechanism of differential locking system

The drive shaft, or propeller shaft, connects the transmission output shaft to the differential pinion shaft. Since all roads are not perfectly smooth, and the transmission is fixed, the drive shaft has to be flexible to absorb the shock of bumps in the road. Universal, or "U-joints" allow the drive shaft to flex (and stop it from breaking) when the drive angle changes.

The rear axle housing includes a flange supporting the. The bearing support the differential bearing assembly and a rear axle bearing assembly and the differential bearing assembly

- Right Hand and Left Hand :-
RH and LH are also called right-hand axle and left hand-axle. When outside shaft rotate on the common axis with the right-hand rear axle. The left- hand rear axle which is also called Left Hand.
- Dog ring:-
It is provide with a single spike for engagement.The shifter mechanism moves the dog ring towards right and dog teeth attach to spike shaft slot. It is provide single spike for engagement.



Figure - Dog ring [6]

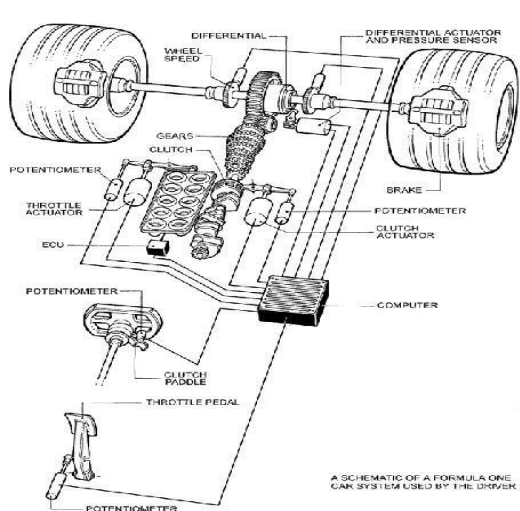

Figure- assembled differential system [6]

5. Function of differential system in a motor vehicle

When the car is taking a turn, the outer wheel will have to travel greater distance as compared to the inner wheel. If the car has solid rear axle only and have no other device there will be tan den cy for the wheel to skid. If wheel skidding is to be avoided, some mechanism should be provided in the rear axle, which should reduce the speed of the inner wheels when the vehicle is taking turn, it should be done at the same time keep the speeds of all the wheel same when going straight ahead.

The details of the differential functions:-

- I. Avoids skidding of the rear wheels on a road while turning.
- II. Reduces the speed of inner wheels and increases the speed of outer wheels, while going to a curve.
- III. Keeps equal speeds of all wheels while moving on a straight stretch.
- IV. Eliminates a single rigid rear axle and provided coupling between two rear axles.

6. Loss of traction in differential system

When one of the wheels goes in a pit condition during the loss of traction or friction between road and wheels .Wheel shaft stops turning.

- a) LH wheel shaft speed increasing then twice the transmission speed vehicle tiers cannot generate enough traction to come out of the pit.
- b) The sensor sense the drop in speed then the electronic relay operated the DC motor.
- c) Shifter mechanism moves the dog ring to the right and dog teeth engage in the shaft slot.
- d) Engagement will lock then the differential action is stop and both wheel shafts get engaged in drive and equal power is given by other wheels.
- e) Wheels After receiving the power pull or push the vehicle out of pit.[7]

7. Advantages of differential system

It can easily move of vehicle, having braking system with slightly modification. It can also give quick response time, control and better than the existing systems. Low grade lubrication oil can be used as heat loss is reduction. Its construction is simple as compared to another part of vehicles like as engines, transmission system etc. Advantages of typical differential system are as following:-

7.1 For open differential

- Simple design
- Reliable
- Few moving parts
- Inexpensive to produce

7.2 For locked differential

- No moving parts, extremely durable and strong
- Maintains constants speed between both wheels

- Produce a stabilization force acting through the real axle, that is resist vehicle rotation

7.3 Limited slip differential

Low friction and high mechanical efficiency is desired in most mechanical system, the differential system desires high friction irrespective of mechanical efficiency.

It is because low friction differential auto vehicle causes limiting acceleration, excessive tyre wear also causes reduce traction over the slippery surface it is also causes excessive wheel spin and fitting of the left hand driving wheel off the uneven road surface due to torque reaction of the engine during acceleration.

The lifting of one wheel may be dangerous to the vehicle. Stability there for provision is made to oppose the differential action by increasing the friction between sun wheel and the differential cage.

Several arrangements have been made to self lock the differential using some frictional device, that allows only a limited slip differential. The name limited slip differential is due to this reason. The consists of a multidisc cone clutch plate fitted adjacent to the sun wheel. Its outer and inner plates are spline to the cage and the wheel respectively.

- Manages vehicles traction mechanically
- Completely passive system, no electrical controller input required[9]

8. Application of differential system

- In Open differential system generally production in car applications, and both trucks and cars
- In Locked differential system also use in off road vehicles, drag racing, oval racing
- In limited slip differential system performance oriented or high end production vehicles and road racing[8]

9. Conclusion

By utilizing the benefits of the independent of the motor driving electric vehicle, differential speed steering is studied to replace traditional mechanical steering in this paper. When the inner and outer wheel are given different speeds, the steering

the steering of four wheel driving electric vehicle. During the differential speed steering with four wheels, the minimum turning radius can be zero for a pivot steering. But greater power and torque are required as a greater sideslip is encountered. Wheel slip plays a critical role in kinematic and dynamic modeling of the steering. Understanding the effect slip of the differential-steering, we can optimize the torque control of the motor to decrease the power consumption and tyre wear. In the future work, the wheel/ground interactions which directly provide traction and braking forces that affect the steering stability and turning radius will be studied. The following conclusions are drawn from the previous chapters:-

- The automatic engagement of the differential when the loss of traction condition.
- And the setup box show the physically over ride using push button for the semi automatic mode for the differential locking system.

References

- [1] "Theory of machines" by khurmi and gupta 2008 revised
- [2] Katsumi Ito, Osaka; Shigeiaki Okuyama, kawachinagano; Norimi Nakamura, Yashizo Kuroiwa; Koushi Fujiwara; Japan(1987). "automatic differential locking system for working vehicle" U.S. patent, no. 4,671,376, 9June 1987.
- [3] Alfred sigl, Sershiem; Germany (1987) ; "Vehicle with lockable differential" U.S. patent, no 4,671,373
- [4] Internet source
- [5] Prof. A.S. Todkar and R.S. Kapare
- [6] Internet source
- [7] Prof. A.S. Todkar and R.S. Kapare
- [8] Notes of Porsche car company