

## **An Application to Wireless Standards for Remote Monitoring For Electric Drive Systems Using Zigbee Standards**

**Imthiazunnisa Begum, Mohammed Qayamuddin, Korani Ravinder, MD Abdul Khader, Zeeshan Ahmed**

M-Tech H.O.D ECE Department, VIFCET JNTU Hyderabad-75 [imthiazunnisa@gmail.com](mailto:imthiazunnisa@gmail.com)

PG Scholar, Embedded System VIFCET JNTU Hyderabad-75 [koraniphd814@gmail.com](mailto:koraniphd814@gmail.com)

M-Tech, Assistant Prof Department of E.C.E JNTU Hyderabad-75 [qayam.baba143@gmail.com](mailto:qayam.baba143@gmail.com)

PG Scholar in VLSI Design Department of E.C.E VIFCET, JNTU Hyderabad-75 [khaderabdulla@gmail.com](mailto:khaderabdulla@gmail.com)

PG Scholar, Embedded System Department of E.C.E VIFCET, JNTU Hyderabad-75 [Zeeshan.suzuki36@gmail.com](mailto:Zeeshan.suzuki36@gmail.com)

**Abstract—This paper discusses an implementation of wireless standards for remote monitoring of electric drives. An appropriate wireless system has been developed and described. It uses ZigBee standard for remote data transmission combined with Internet connectivity for assessment of the Global network-collected information. The designed measuring devices and the respective sensors are also presented. Algorithms have been developed allowing evaluation of additional parameters using data from the measurements held. Detailed experimental studies confirm the good performance of this monitoring system. The research carried out as well as the results obtained can be used in design and set up of such types of wireless monitoring systems. Keywords—Intelligent sensors, End-device, Coordinator device, ZigBee network, Measurement system, Remote monitoring**

### **I. INTRODUCTION**

With the modern development of wireless technologies and devices, wireless sensor networks become very popular for a variety of practical applications [1]-[3]. Wireless devices using standards like ZigBee are widely used in measurement equipments because of their capabilities to provide very low energy consumption, easy maintenance, data encryption, diverse network topologies, etc. Another benefit of the ZigBee networks is that they allow monitoring parameters of different devices. They are also characterized by much faster installation in comparison with the wired systems, which can take days or weeks to install. ZigBee networks require only the end points to be installed saving users much time. Wireless sensing and control are especially useful in cases where the monitored objects are situated in remote and hardly accessible places. Effective applications of

wireless sensor networks are described in [4], [5]. Nowadays, such wireless systems are often applied for monitoring and control in many areas: manufacturing processes, robotics, building automation, etc. Some implementations of wireless control in industry for robots and manipulation systems are described in [6], [7]. An industrial real-time measurement and monitoring system based on ZigBee standard is presented in [8]. An increased interest in this standard for building automation has been registered recently [9]. Remote wireless systems are also suitable for monitoring of various environmental parameters such as: air pollution, humidity, temperature, pressure, etc. [11]. Especially, for monitoring of electric drive systems, measurement of parameters such as voltage, current, torque, speed, position, distance, temperature, energy consumption, battery charge and vibrations may be required. Some applications of appropriate devices for wireless data transfer are described in [12]-[14]. This paper presents the design of a modular

wireless sensing system for monitoring of electric drives suitable for industrial and home applications. It uses ZigBee standard for remote data transmission combined with Internet connectivity for assessment of the Global network-collected information. The system developed includes a ZigBee network of intelligent measurement modules combined with a coordinator device with GSM or Ethernet modem. The ZigBee standard provides high reliability and immunity against any narrow-band interferences. A coordinator device realizes data acquisition and the network management. It also expands the low-range ZigBee network to a widespread range. The system measurement devices can be installed at almost any place because of their compact sizes. In addition, the monitoring system flexibility allows its utilization in a variety of practical applications.

## II. DESIGN OF THE MEASUREMENT SYSTEM

The general structure of the developed wireless sensor system is presented in Fig. 1. It consists of one wireless data collection module (ZigBee coordinator device), end-devices (measuring devices), database server which is accessed via Internet and a module for system control and data visualization. The coordinator device reads data measured from remote end-devices and retransmits them to the database server. The wireless connection between end-devices and the coordinator device is facilitated through their ZigBee modules. The database server and the coordinator device can be connected in three ways: through a personal computer, an Internet modem or a GSM/GPRS modem. This measurement system includes three communication modules (GSM/GPRS, ZigBee and Ethernet modem) and several end-devices for monitoring temperature, inclination, voltage and current. Such a modular concept allows combining the different types of measuring devices with various communication capabilities according to certain environmental conditions and requirements. Each of the measuring devices

can be used independently or as a part of the complex system.

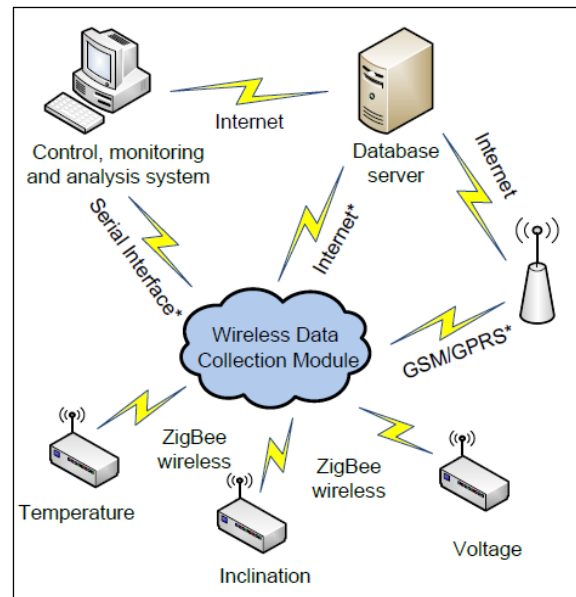

**Fig. 1** Structure of the wireless measuring system.

- **Microcontroller:** Its main task is to acquire sensor data and to manage the ZigBee wireless network. It implements radio channel configuration, end-device association, network ID and end-device ID configuration, remote sensor data acquisition, etc. The microcontroller also performs control and configuration of the different communication modules (ZigBee, GSM/GPRS and Ethernet).

- **ZigBee:** The ZigBee module is used to facilitate wireless connection between the coordinator device and the measuring end-devices. It is controlled via standard AT commands over a serial communication interface. It has very low power consumption and is suitable for battery powered systems.

- **GSM/GPRS:** This module is used as a gateway between the ZigBee and the database server. It is controlled via standard AT commands over a serial communication interface. It is applied to retransmit the acquired sensor data over the mobile cellular network to the Internet connected database using the GPRS data channel. The module provides mobility of the designed system.

- **Ethernet:** This component facilitates a direct access to the database server. The developed measuring system utilizes SNMP protocol on the application layer. The measured data is transmitted from the coordinator device to the

Ethernet module via serial line. After that it can be read and saved in the database through the SET and GET SNMP commands. A specially developed program script is designed for data acquisition from the coordinator device via Ethernet interface.

□ **Sensors and input measuring channels:** The coordinator device incorporates two temperature channels for monitoring the ambient temperature and the temperature of a monitoring device. The system uses digital temperature sensors, SMT-160 which provides accuracy of about +/- 0.7 °C and supply current of about 200. A □

The coordinator device has one current input which can be used for connection with a current transducer such as LA 125-P. This sensor uses Hall closed-loop technology and provides accuracy of about +/- 1 A in the entire measuring range of -125 to +125 A. The current input can also be used as an information input connected to a standard industrial device with 0/4 ÷ 20 mA analog output. The second analog input is used to measure voltage. It can be configured to measure voltages in the range of 0 to 300 VDC, depending on the input divider. Together with the current input it can also be used to measure charge/discharge cycles of various accumulator batteries. The voltage input as a current input may be used as information input. In this case, the coordinator device should be connected to a standard industrial device with analogue voltage output in the range 0 ÷ 10 VDC.

□ **Real time clock and EEPROM:** Real time clock (RTC) implements the time synchronization. When this device is used as a data logger, it defines the measurement interval between two adjacent data samples. The RTC has internal RAM with independent backup power supply allowing it to store device parameters such as calibration constants, logging time interval, etc.

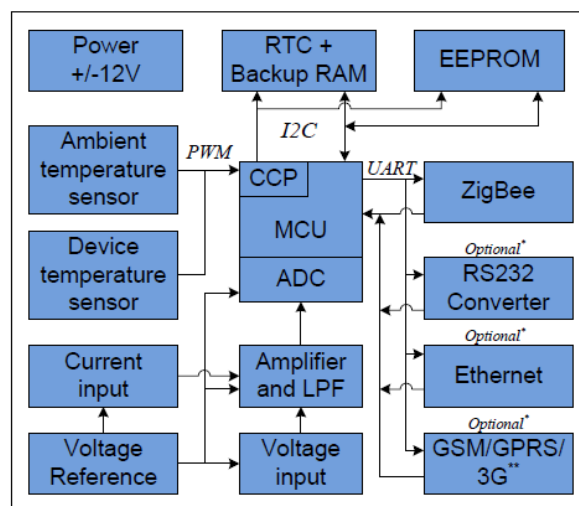

**Fig. 2** Block diagram of the data collection module (Coordinator device).

EEPROM is used for storing the measured data. The user can select which data channels to be saved and the time interval between two samples of the measured data.

□ **Power supply:** In order to implement its full functionality, the coordinator device is powered by +/- 12 VDC. Such a bipolar voltage is required by the current sensor LA 125-P. In case that this input is not implemented, the device can utilize only +12 V power supply.

## B. End-devices

The block diagram of one of the end-measuring devices is shown in Fig. 3. Its major purpose is to measure temperature from resistive temperature sensors such as platinum sensors or thermistors. Unlike the digital temperature sensors of the coordinator device, the end-device resistive sensors achieve greater accuracy (platinum) and faster response time (thermistors). Depending on the system's measuring requirements, either the much more accurate platinum sensors or low cost thermistors for temperature measurement can be implemented.

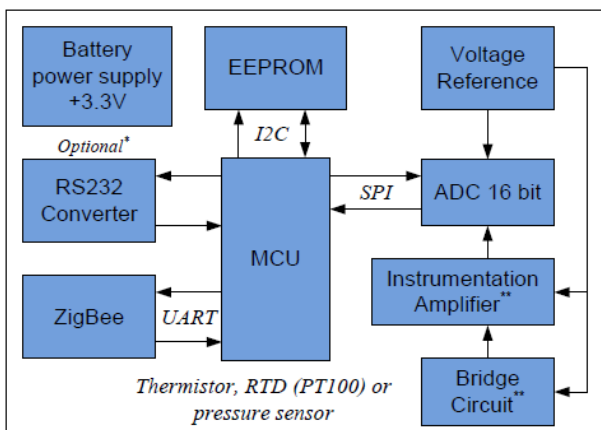

Fig. 4 shows the scheme of an input temperature channel. In order to reduce errors caused by the connecting wires resistance, the platinum sensors are connected in bridge circuit using 3-wire connections [10]. On this figure, each wire is represented as a resulting resistance  $R_{w1}$ ,  $R_{w2}$  and  $R_{w3}$ . Given that  $R_{w1}$  and  $R_{w2}$  are equal, as well as the currents flowing through them, the respective voltage drops compensate each other. The sensing analog channel consists of one instrumentation amplifier and a 16 bit analog to digital converter. The input channel can be used with thermistors and depending of the sensor only the bridge values must be recalculated. The microcontroller software must also be changed.

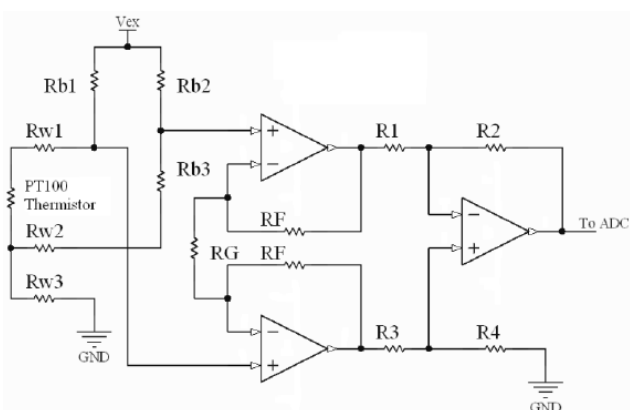
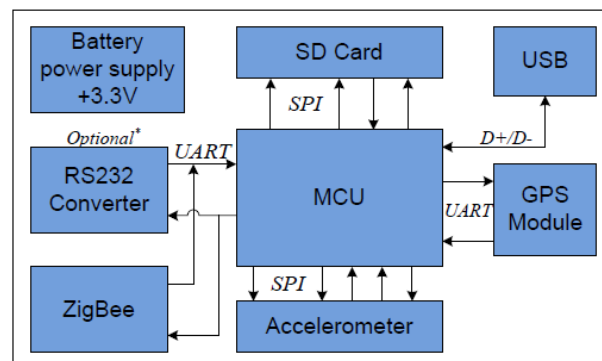

Fig. 5 illustrates the block diagram of an acceleration end-measuring device. It consists of a 3-axis digital accelerometer, LIS3LV02DQ. The device implements two types of measurements – acceleration for calculating the inclination of

monitored objects (especially platforms) and vibrations of various machines (especially electrical motors). In the example given for an acceleration measurement, 40 samples per second and 640 samples per second are used for inclination and vibration respectively.



Due to the large amount of information, a SD card is used to store the measured data and send it to the ZigBee coordinator at a certain moment. However sending data is a battery consuming operation, therefore the amount of transmitted data should be taken into account. A GPS module is implemented in the mobile application. Together with the inertial sensor it can be used for off-line vehicle tracking. In order to preserve energy, all battery powered devices work based on the following algorithm: data measurements are performed in strict time intervals; hourly collected data are stored into the EEPROM (in case of battery or other failure only the last hour data will be lost); data are acquired from the end-devices once a day or in longer periods of time to preserve the battery energy. The ZigBee devices have low-power consumption. However, transmitting data over radio channels decrease battery life.

### III. EXPERIMENTAL RESULTS AND PERFORMANCE ANALYSIS

With the system developed various parameters of electric drive systems can be measured and many others could be calculated based on them. Some graphical presentations of sensors-acquired data and algorithms for evaluation of additionally monitored parameters are given. Ambient temperature is measured simultaneously by the coordinator device and the end-device (Fig. 6).

Both have different types of temperature sensors and are placed at a distance from each other in a room with operating electrical motors. The time diagrams illustrate a constant offset of about 20 C between the two measured temperatures. This is because of their different location and the lower accuracy of the digital sensor (SMT160) in comparison with the resistive one (platinum). The illustrated data in Fig. 6 have been collected in a period of 14 hours with an interval of one minute. The sensing network started collecting data at night and stopped after 14 hours. According to the graphic, the daylight cycle began around the 100th minute. The temperature's increase indicates the sunrise. From the presented values it can be concluded that during the day the working environment temperature reaches up to 47oC.

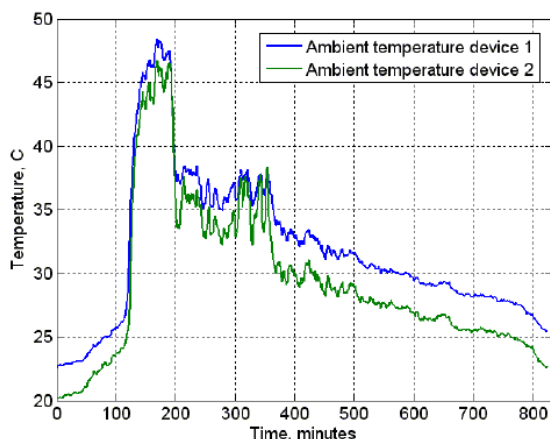

An advantage of this wireless system is that an accurate temperature measuring device can be used or a low cost one depending on the particular user requirements. Fig. 7 presents experimentally obtained results from remote temperature monitoring of an induction motor in an AC electric drive system with frequency control. In this driving system a three phase voltage source inverter with tracking pulse width modulation is used. In the interval shown both motor and ambient temperatures are tracked.

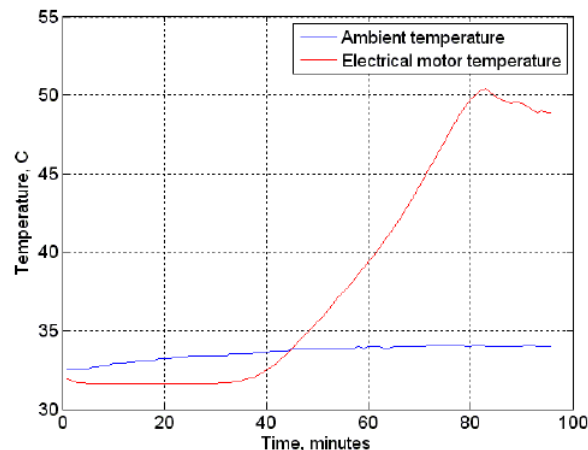
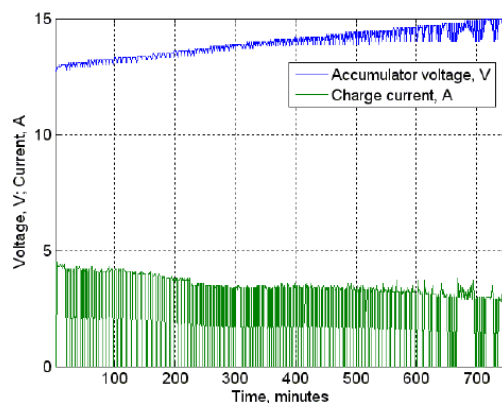

Fig. 8 presents results from a measurement of direct current and voltage. In the particular case a 12 V lead-acid accumulator battery is monitored during its charge cycle. In industry such monitoring of batteries' charge-discharge cycles is very important to expand their period of use and to prevent battery powered system failures. Using the measured current and voltage values the battery energy during its charge-discharge cycle can be calculated by the following equation:

$$E = \sum_{i=1}^n U_b [i] I_{c/d} [i] \Delta t, \quad (1)$$

where:  $U_b$  is battery voltage;  $I_{c/d}$  - charge/discharge current;  $\Delta t$  - discrete time.



With electric drive systems accumulator batteries are used to supply DC/DC and DC/AC power converters such as transistor choppers and inverters, especially in electric cars. Acceleration measuring results shown in Fig. 9 are obtained from the system's inertial sensor while it was rotated on one of its axis - in particular Y axis. The graphic shows a constant offset of the axis. This means that for the device's proper functioning, a



calibration procedure is required by setting the inertial sensor in horizontal position, evaluating its data and subtracting the constant offset from the measured results in working mode.

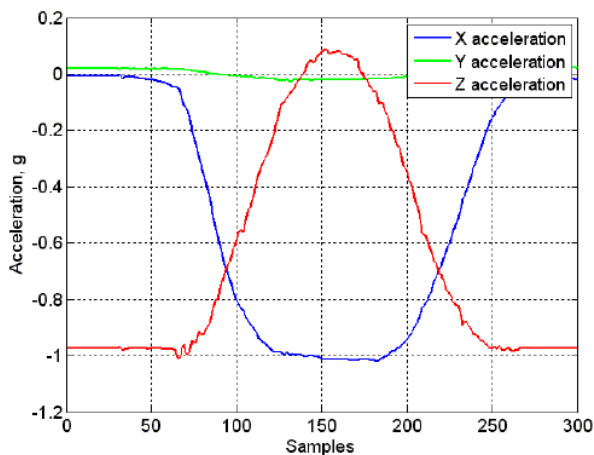

The data presented in Fig. 9 can be used for calculation of the inclination of various platforms according to the following equation:

$$\alpha = \arccos(x/G) \quad (2)$$

Equation (2) presents computation of the X-axis angle. G is Earth gravity and x is the sensor value for this axis acceleration. Fig. 10 illustrates the spectral analysis of electrical motor vibrations. This motor is a part of the monitored drive system consisting of thyristor power converter and separately excited DC motor. The two curves indicate motor's proper operation and the vibration spectral components, when the motor is not stably fixed. Without proper fixing of the motor there is evident increasing of vibrations.

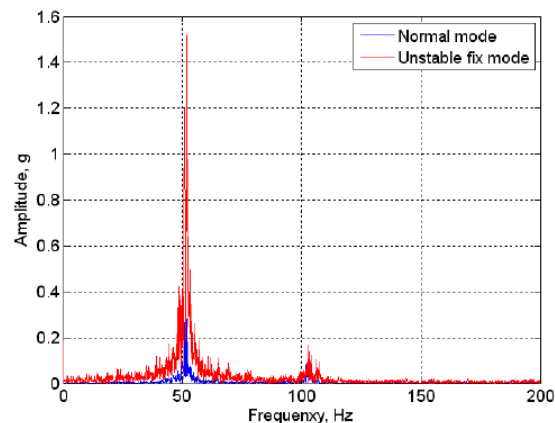

Remote vibration measurement allows monitoring of the electrical motors fixing to the respective fundamentals as well as the condition of their bearings.

#### IV. CONCLUSION

A system for remote monitoring of electric drives has been developed and described. The structure presented is flexible due to the utilized wireless standards and allows measurement of all their parameters such as voltage, current, speed, temperature, energy consumption, vibrations, etc. Appropriate algorithms have been developed for evaluation and analysis of additional characteristics using data from the measurements held. Detailed experimental studies confirm the good performance of this wireless system. The research carried out as well as the results obtained can be used in design and set up of such types of remote monitoring systems for electric drives in industry and home applications.

#### ACKNOWLEDGMENT

This work has been supported by the Technical University of Sofia, Project No. 121PD0067-07/2012.

#### REFERENCES

[1]. A. Elahi and A. Gschwender, *ZigBee Wireless Sensor and Control Network*, Englewood Cliffs, Prentice Hall, 2009.

- [2]. S. Farahani, *ZigBee Wireless Networks and Transceivers*, Burlington, Newnes, 2008.
- [3]. H. Karl and A. Willig, *Protocols and Architectures for Wireless Sensor Networks*, West Sussex, Wiley, 2007.
- [4]. P. Zahariev, G. Hristov, M. Iliev and I. Tsvetkova, "Extending the lifetime of wireless sensor networks by mechanisms for routing the information in more energy efficient ways," in: *Proceedings of MIC-CCA'11*, pp. 73 – 78, Istanbul, Turkey, 2011.
- [5]. G. Hristov, P. Zahariev, T. Iliev and M. Iliev, "An approach for energy optimization in wireless sensor networks," in *Proceedings of ICITTEM'10*, pp. 203 – 206, Opatija, Croatia, 2010.
- [6]. C. Hernandez, R. Poot, L. Narvaez, E. Llanes and V. Chi, "Design and Implementation of a System for Wireless Control of a Robot," *International Journal of Computer Science*, Vol. 7, No. 5, pp. 191-197, 2010.
- [7]. K. Belda, V. Rychnovsky and P. Pisa, "Wireless Communication for Control of Manipulation Systems," *Archives of Control Sciences*, Vol. 22, No. 1, pp. 29-41, 2012.
- [8]. W. Sung and Y. Hsu, "Designing an industrial real-time measurement and monitoring system based on embedded system and ZigBee," *Expert Systems with Applications*, Vol. 38, No. 4, pp. 4522-4529, 2011.
- [9]. D. Egan, "The emergence of ZigBee in building automation and industrial control," *Computing Control Engineering Journal*, Vol. 16, No. 2, pp. 14-19, 2005.
- [10]. P. Sapundjiev, "Air Humidity Measurement Using the Psychrometric Method," in *Proc. ELECTRONICS'09*, Vol. 1, pp. 168-171, 2009.
- [11]. H. Zhi-gang and C. Cai-hui, "The Application of ZigBee Based Wireless Sensor Network and GIS in the Air Pollution Monitoring," in *Proceedings of ICESIAT'09*, pp. 546-549, Wuhan, China, 2009.
- [12]. M. Mikhov and L. Pachemanov, "Two-Coordinate Driving System with Wireless Control," *Annals of the University of Targu-Jiu*, Vol. 10, No. 3, pp. 180-188, 2010.
- [13]. B. Zaineb, B. Mouna and L. Sbita, "Wireless Control for an Induction Motor," *International Journal of Electrical and Electronics Engineering*, Vol. 5, No. 1, pp. 1-5, 2011.
- [14]. R. Bayindir and M. Sen, "A Parameter Monitoring System for Induction Motors Based on ZigBee Protocol," *Gazi University Journal of Science*, Vol. 24, No. 4, pp. 763-771, 2011.