

Implementation of Data Acquisition System with a Free Cooling Unit (FCU) Controller For a BTS

Imthiazunnisa Begum, Zeeshan Ahmed, Korani Ravinde MD Abdul Khader, Mohammed Qayamuddin

M-Tech H.O.D ECE Department, VIFCET JNTU Hyderabad-75

imthiazunnisa@gmail.com

PG Scholar, Embedded System Department of E.C. E JNTU Hyderabad-75

zeeshan.suzuki36@gmail.com

M-Tech, Assistant Prof VIFCET JNTU Hyderabad-75

koraniph814@gmail.com

PG Scholar in VLSI Design Department of E.C. E VIFCET, JNTU Hyderabad-75

khaderabdulla@gmail.com

PG Scholar, Embedded System Department of E.C. E VIFCET, JNTU Hyderabad-75

qayam.baba143@gmail.com

Abstract— The scarcity of electricity causing serious dislocation in all spheres of life, including production in agriculture and industries as well as in the section of cellular communication. To reduce the wastage of electricity in BTS room now-a-days cellular operators are using different ventilation systems instead of Air Conditioner (AC). Recently many operators like Banglalink, a leading telecom operator in Bangladesh are interested to interface a data acquisition system with these ventilation systems in BTS rooms. So in this paper a modern ventilation system FCU is designed interfacing with a Micro SD card for data acquisition especially for Banglalink BTS. FCU is an electronic instrument that records the temperature data and takes decision according to that data. This research work deals with the PIC18F4520 which includes 10 bit ADC for data conditioning and 32K bytes of program memory which provides the advantage of interfacing a FAT-16 system with microprocessor. In display section 4X20 LCD display is used for user interaction

Index Terms— Air Conditioner, BTS, Free Cooling Unit, Intelligent Ventilation System, LCD, Microprocessor, Micro SD Card.

1 Introduction

Free Cooling Unit is a ventilation system dedicated to the tele-com BTS [1]. The main objective of free cooling is to reduce AC run time and save electricity cost at the BTS sites [2]. It also can reduce the carbon emission as like as the IVS (Intelligent Ventilation System) used in Robi, another leading telecom operator in Bangladesh which is really an environment friendly feature [3].

A special feature is now added with this ventilation system which is data acquisition. Data

acquisition systems, as the name implies, are products and/or processes used to collect information to document or analyze some phenomenon [4]. So by using this data logger system we can store millions of data of BTS room temperature as well as outside temperature including the relevant date and time and also can collect those data for further analysis and improvement.

So Free Cooling Unit (FCU) controller is a microcontroller based electronic system that maintains the overall environment of a BTS room by controlling a Fan Unit, a Filter Unit and an AC by observing the room temperature and battery voltage level of a BTS room. It also contains a data acquisition unit using SD card [5].

2 Proposed System

The FCU is made up of the following major components;

Controller Unit: Controller Unit monitors the whole environ-ment of the BTS room and manages the room temperature by controlling the Fan Unit, Filter Unit and the Air Conditioner. It also contains a data logging section

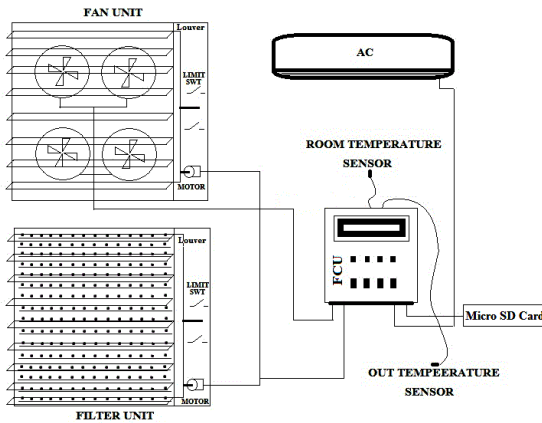

Fig. 1. Total Free Cooling Unit (FCU) system .

Fan Unit: This equipment first opens the louver by using a twelve volt DC motor when a Fan Run Signal comes from the controller. The rotation of the motor is conjusted in a certain level using limit switch. Fig. 1 shows the total FCU system.

Filter Unit: Filter Unit also opens the louver initially as same as the Fan Unit. Next it maintains a dust free air circulation in the BTS room.

Air Conditioner (AC): Although it is not the part of a FCU but still its operation is maintained by the Controller Unit. Now-a-days most of the BTS do not contain an AC as well.

3 Hardware Design

3.1 Power Supply Section

Most of the BTS rooms contain battery of 48 volt or 24 volt DC to give support when the PDB is unavailable. So it is necessary to convert this 48 volt or 24 volt DC to a 12 volt DC to run the controller circuit. This power supply is used to run the motor of the louver as well as it give support

to the 5 volt DC section of the controller. We can easily convert the 12 volt DC to 5 volt DC by using LM7805 IC. Fig. 2 shows a power supply section.

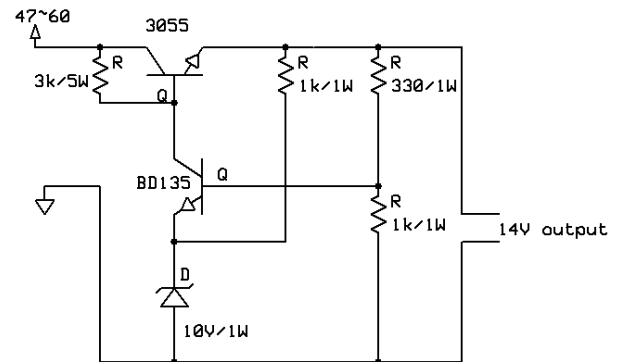

Fig. 2. Power supply section

3.2 Reset Section

It is a special feature of this contorller. It works as an external watchdog timer which can reset the whole system when ever it enters in to a forever loop. It is designed with HEF4047B which is an astable or monostable multivibrator IC [6] and used as an edge detector in this section.

3.3 Main Controller

The control module is built with the microcontroller IC. The central controller is Microchip PIC18F4520. PIC18F4520 is an enhancaed flash microcontroller with a 10 bit A/D converter and nano technology [7]. It consists of 36 I/O (Bi directional lines) with 25mA current in per pin. It also has 13 channel built-in A/D converter and 32kbytes of program memory.

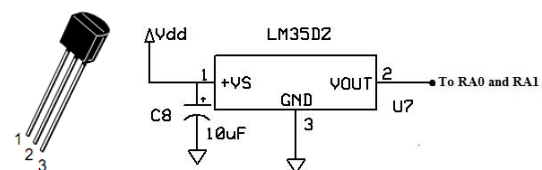

Fig. 3. Pin Configuration and Connection diagram of LM35DZ

3.4 Sensor Section

For measuring the temperature, FCU controller required two LM35DZ sensors shown in fig. 3. One is for the room tempera-ture and another is used to measure the outdoor temperature. The LM35 series are precision integrated-circuit temperature sensors, whose output voltage is linearly proportional to the Celsius (Centigrade) temperature [8]. Temperature is directly measured by the AN0 and AN1 pin of microcontroller IC.

3.5 Battery Voltage Monitor Section

Battery voltage level monitoring section shown in fig. 4 is one of the important part of this device. In this section we have used a 5kohm multiturn which provides fine resistance adjustment [9]. So we can monitor the battery voltage level of a BTS room precisely.

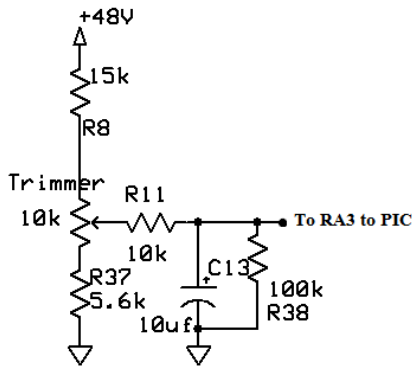

Fig. 4. Battery Voltage monitoring Section

3.6 Data Acquisition Section

To store the room temperature and outdoor temperature data consecutively a micro SD card shown in fig. 5 is used with an adapter in this controller. The microSD memory Card is a functionally compatible with the SD Memory Card but is smaller in dimensions [10]. The microSD memory Card communication is based on an advance 8-pin interface and the microSD memory Card host interface supports regular SD or miniSD Memory Card Adapter and operates as an SD Memory Card. The capacity of microSD/TransFlash memory cards currently range in storage size from 64 MB (megabytes) to 8GB (gigabytes) and upward [11]. In this project a 2GB micro SD card is used and to interface the SD card with PIC18F4520 an adapter is also used.

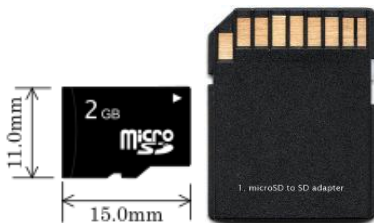

Fig. 5. Micro SD card and Adapter

3.7 Display Section

For display section a 4x20 line LCD (Liquid Crystal Display) is used. LCD is now a very common choice for graphical and alphanumeric displays. Generally LCD is a high contrast control

module with a 4-bit or 8-bit data bus and built in temperature control module [12].

3.8 Fan Driving Section

This section is designed to provide a 48 volt battery voltage to the Fan Unit when it is required shown in fig. 6. This is executed by the main controller through the logic execution.

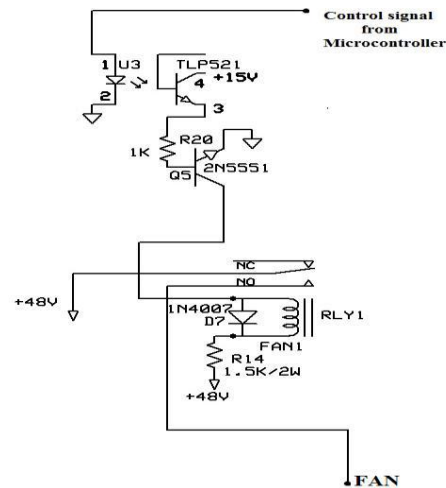

Fig. 6. Fan Driving Section

3.9 AC Driving Section

For AC driving a 3-phase 120 ampere DC relay is used which operates at the coil voltage of 12 volt shown in fig.7



Fig. 7. AC Driving Relay [13]

3.10 Motor Driving Section

To open the hood of the louver a low RPM (at least 10 RPM) motor is used whose operating voltage and direction is controlled by the main controller shown in fig. 8.

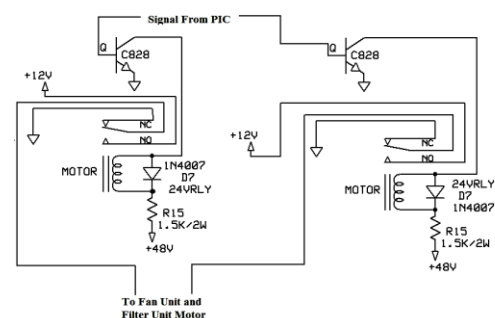
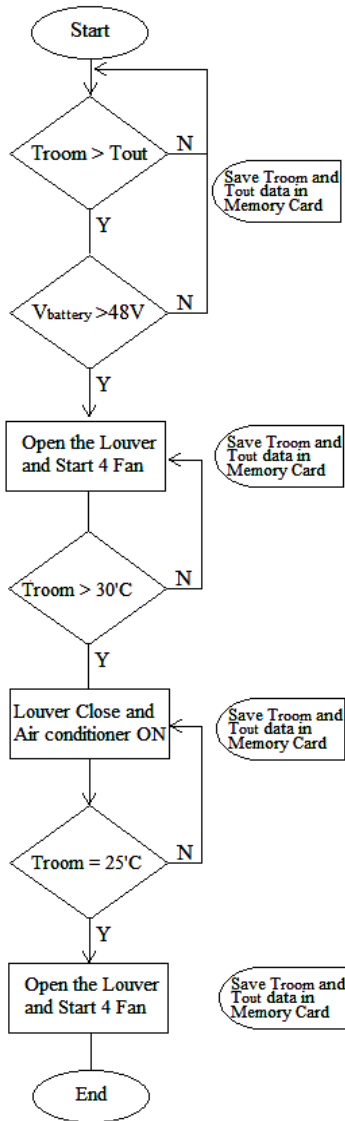

Fig. 8. Motor Driving section

4. Logic Flow Chart



5 Working Principle

The PIC microcontroller 18F4520 always senses the room temperature and outdoor temperature using its 10 bit A/D converter. It also monitors the battery voltage level as well. It is important because the Fan Unit will not work if the BTS battery voltage is under some certain specified level. The controller also maintains the room temperature under a predetermined value by controlling the Fan Unit and Filter unit operation. It also controls the movement of louver. If the BTS room temperature is not under a tolerant level then the controller gives priority to AC rather than Fan and Filter Unit. One of the major operations of this controller is to store the room

temperature and outdoor temperature data with relevant time and date in to a micro SD card.

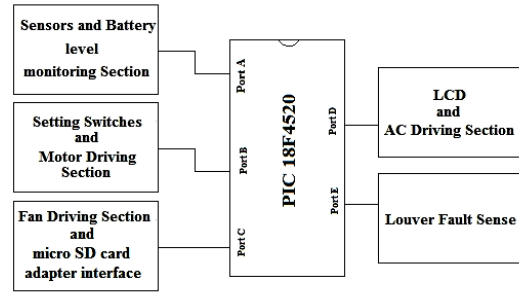

Fig. 9 shows the overall system.

6 Experimental Setup

The experimental setup of the controller unit is shown in fig. 10. One LCD display is used to display time, date, temperature and other required outputs. Fig. 11 shows four fans and the filter unit. Filter unit always helps to filter dust and other unwanted particles.

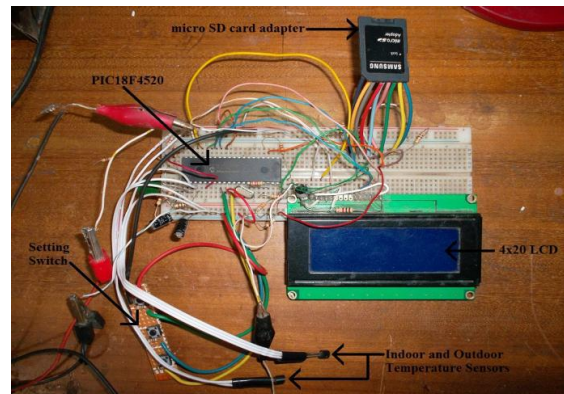

Fig. 10. Practical setup of the Controller Unit



Fig. 11. Fan Unit and Filter Unit

7 RESULT

Fig. 12 shows the digital display results in the LCD display. In the display unit it shows the inside and outside temperature of the BTS room. The controller unit takes the necessary action to cool the BTS room by using cooling fans.

```

fcu - Notepad
File Edit Format View Help
Time:12:47,DATE:1/12,ROOM TEMP:24'C,OUTTEMP:22'C;
Time:12:49,DATE:1/12,ROOM TEMP:24'C,OUTTEMP:23'C;
Time:12:51,DATE:1/12,ROOM TEMP:24'C,OUTTEMP:24'C;
Time:12:53,DATE:1/12,ROOM TEMP:24'C,OUTTEMP:24'C;
Time:12:55,DATE:1/12,ROOM TEMP:24'C,OUTTEMP:23'C;
Time:12:57,DATE:1/12,ROOM TEMP:24'C,OUTTEMP:24'C;
Time:12:59,DATE:1/12,ROOM TEMP:24'C,OUTTEMP:24'C;
Time:13:01,DATE:1/12,ROOM TEMP:24'C,OUTTEMP:23'C;
Time:13:03,DATE:1/12,ROOM TEMP:24'C,OUTTEMP:23'C;
Time:13:05,DATE:1/12,ROOM TEMP:24'C,OUTTEMP:23'C;
Time:13:07,DATE:1/12,ROOM TEMP:24'C,OUTTEMP:23'C;
Time:13:09,DATE:1/12,ROOM TEMP:25'C,OUTTEMP:24'C;
Time:13:11,DATE:1/12,ROOM TEMP:25'C,OUTTEMP:24'C;
Time:13:13,DATE:1/12,ROOM TEMP:25'C,OUTTEMP:24'C;
Time:13:15,DATE:1/12,ROOM TEMP:26'C,OUTTEMP:24'C;
Time:13:17,DATE:1/12,ROOM TEMP:26'C,OUTTEMP:23'C;
Time:13:19,DATE:1/12,ROOM TEMP:26'C,OUTTEMP:23'C;
Time:13:21,DATE:1/12,ROOM TEMP:26'C,OUTTEMP:23'C;

```



References

[1] kk_Free_Cooling_FC-T5,_FC-T2,5_ENG__v3.0.pdf, [Online], Available: www.telzas.com

[2] Free cooling.pdf, Bharat Sanchar Nigam Ltd.New Delhi.

[3] Michael Kuehner, “Roby of Bangladesh reduces CO2 emission by 30 percent in 2010”, 2011-06-21.

[4] Data Acquisition Systems, [Online]available: www.omega.com

[5] Dogan Ibrahim, “SD Card Projects Using the PIC Microcontroller”, www.elsevier.com.

[6] HEF4047B, “MSI Monostable/astable multivibrator”,Jan 1995.

Fig. 12. LCD Output

8 Conclusion

FCU is an environment friendly ventilation system for BTS rooms. It not only reduces the emission of carbon-di-oxide (CO2) in environment but also saves electricity in a great deal. The whole package of FCU is not very costly and it could be an affordable choice for a developing country like Bangladesh. Its data acquisition system is an advance feature which not only helps to monitor the BTS room environment but also can provide ideas how to improve the function of the FCU system. So replacing an Air Conditioner with a Free Cooling Unit will be a profitable choice for our environment and economy as well

[7] PIC18F2420/2520/4420/4520, Microcontrollers with 10-Bit A/D and nanoWatt Technology”, 2007 Microchip Technology Inc.

[8] LM35, “Precision Centigrade Temperature Sensors”, Natinal Semi-conductor, November 2000.

[9] Multiturn vs. Single-turn, <http://www.bourns.com/archive.aspx>

[10] Shafik G. Punja & Richard P. Mislán, “Mobile Device Analysis”, SMALL SCALE DIGITAL DEVICE FORENSICS JOURNAL, VOL. 2, NO. 1, JUNE 2008 ISSN# 1941-6164

[11] MicroSD Card Rev1.01, www.pqi.com.tw

[12] LCD MODULE 4x20 - 3.73mm, Available: www.lcd-module.de

[13] Electromagnetic-Relay, Available: www.sungko.com