

## **Design, Planning, Machining, and Manufacturing Using Rapid Prototyping Technologies in Modern Engineering**

*Md.Hira Hashimi , Md Abdul Basith*

### **ABSTRACT**

The term rapid prototyping (RP) refers to a class of technologies that are used to produce physical objects layer-by-layer directly from computer aided design (CAD) data. These techniques allow designers to produce tangible protons of their designs quickly, rather than just two-dimensional pictures. Besides visual aids for communicating ideas with co-workers or customers, these prototypes can be used to most various aspects of their design, such as wind tunnel tests and dimensional checks. In addition to the production of prototypes, rapid prototyping techniques can also produce molds or mold inserts (rapid tooling) and even fully functional end parts (rapid manufacturing).

In rapid prototyping, the term “rapid” is relative; it aims at the automated step from CAD data to machine, rather than at the speed of the techniques. Depending on the dimensions of the object, production times can be as long as a few days, especially with complex parts or when long cooling times are required. This may seem slow, but it is still much faster than the time required by traditional production techniques, such as machining. This relatively face production allows analyzing parts in a very early stage of designing, which decreases the resulting design cost. The costs can also be reduced because rapid prototyping processes are may automated and therefore, this need the skill of individual craftsmen for no more than finishing the part.

**Keywords :** Rapid Prototyping, Liquid, Solid and Power based prototyping.

### **1. Introduction**

Rapid prototyping is a group of techniques to used quickly fabricate a scale model of a physical part or assembly using three-dimensional computer aided design (CAD) data. Construction of the part or assembly is usually done using 3D printing or "additive layer manufacturing" technology.

Rapid prototyping, is a collection of processes used to fabricate a model, part, or tool in minimum possible time. These technologies used in electronics manufacturing, an activity of significant economic importance. Some of the technologies used to produce very small parts and products. It describes microfabrication technologies used to produce items measured in microns (10-6 m), whereas nanofabrication technologies for producing items measured in nanometers (10-9 m).

Rapid prototyping dates from about 1988. Finally, the nano fabrication technologies represent an emerging field today that dates from the 1990s.

Here is the principle and process which is been explained in detail about the procedure followed in rapid prototyping (RP).Where, designing the part using the CAD and analyzing it and sending the design for machining and manufacturing it.

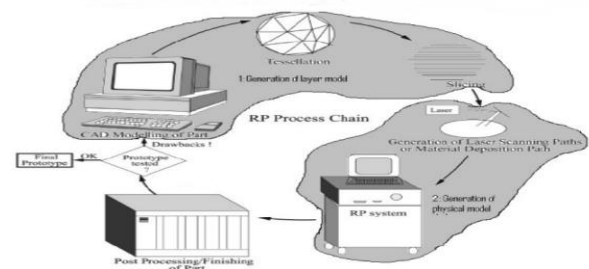

**Figure 1: Principle and Process of Rapid Prototyping**

[Rapid prototyping (RP) is a family of fabrication methods to make engineering prototypes in minimum possible lead times based on a computer-aided design (CAD) model of the item. The traditional method of fabricating a prototype part is machining, which can require significant

lead times up to several weeks, sometimes longer, depending on part complexity, difficulty in ordering materials, and scheduling production equipment.

A number of rapid prototyping techniques are now available that allow a part to be produced in hours or days rather than weeks, given that a computer model of the part has been generated on a CAD system.

## 2. Fundamentals Of Rapid Prototyping

The special need that motivates the variety of rapid prototyping technologies arises because product designers would like to have a physical model of a new part or product design rather than a computer model or line drawing. The creation of a prototype is an integral step in the design procedure.

A virtual prototype, which is a computer model of the part design on a CAD system, may not be adequate for the designer to visualize the part. It certainly is not sufficient to conduct real physical tests on the part, although it is possible to perform simulated tests by finite element analysis or other methods.

Using one of the available RP technologies, a solid physical part can be created in a relatively short time (hours if the company possesses the RP equipment or days if the part fabrication must be contracted to an outside firm specializing in RP). The designer can therefore visually examine and physically feel the part and begin to perform tests and experiments to assess its merits and shortcomings.

Available rapid prototyping technologies can be divided into two basic categories:

- (1) Material removal processes.
- (2) Material addition processes.

The material removal RP alternative involves machining, primarily milling and drilling, using a dedicated Computer Numerical Control (CNC) machine that is available to the design department on short notice.

To use CNC, a part program must be prepared from the CAD model. The starting material is often a solid block of wax, which is very easy to machine, and the part and chips can be melted and resolidified for reuse when the current prototype is

no longer needed. Other starting materials can also be used, such as wood, plastics, or metals (e.g., a machinable grade of aluminum or brass). The CNC machines used for rapid prototyping are often small, and the terms desktop milling or desktop machining are sometimes used for this technology.

### Starting materials include:

- (1) Liquid monomers that are cured layer by layer into solid polymers.
- (2) Powders that are aggregated and bonded layer by layer.
- (3) Solid sheets that are laminated to create the solid part.

In addition to starting material, what distinguishes the various material addition RP technologies is the method of building and adding the layers to create the solid part. Some techniques use lasers to solidify the starting material, another deposits a soft plastic filament in the outline of each layer, while others bond solid layers together. There is a correlation between the starting material and the part building techniques, as we shall see in our discussion of RP technologies.

The common approach to prepare the control instructions in all of the current material addition RP techniques involves the following steps:-

### Geometric Modeling :

This consists of modeling the component on a CAD system to define its enclosed volume. Solid modeling is the preferred technique because it provides a complete and unambiguous mathematical representation of the geometry. For rapid prototyping, the important issue is to distinguish the interior (mass) of the part from its exterior, and solid modeling provides for this distinction.

### Tessellation of the geometric model:

In this step, the CAD model is converted into a format that approximates its surfaces by triangles or polygons, with their vertices arranged to distinguish the object's interior from its exterior. The common tessellation format used in rapid prototyping is STL, which has become the de facto standard input format for nearly all RP systems.

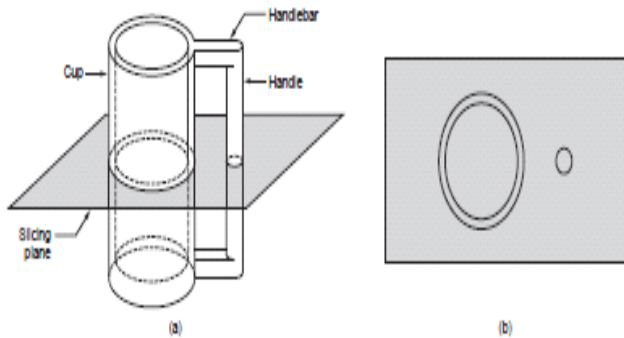

**Figure 2:** Conversion of a solid model of an object into layers.

### Slicing of the model into layers:

In this step, the model in STL2 file format is sliced into closely spaced parallel horizontal layers. Conversion of a solid model into layers is illustrated in Figure 1. These layers are subsequently used by the RP system to construct the physical model.

By convention, the layers are formed in the x-y plane orientation, and the layering procedure occurs in the z-axis direction. For each layer, acquiring path is generated, called the STI file, which is the path that will be followed by the RP system to cure the layer.

There are several different technologies used for material addition rapid prototyping. This heterogeneity has spawned several alternative names for rapid prototyping, including layer manufacturing, direct CAD manufacturing, and solid freeform fabrication. The term rapid prototyping and manufacturing (RPM) is also being used more frequently to indicate that the RP technologies can be applied to make production parts and production tooling, not just prototypes.

### 3. Liquid-Based Rapid Prototyping Systems

The starting material in these technologies is a liquid. About a dozen RP technologies are in this category, of which we have selected the following to describe:

- (1) Stereolithography.
- (2) Solid ground curing.
- (3) Droplet deposition manufacturing.

#### 3.1. Stereolithography

This was the first material addition RP technology, dating from about 1988 and

introduced by 3D Systems, Inc. based on the work of inventor Charles Hull. There are more installations of stereolithography than any other RP technology.

Stereolithography (STL) is a process for fabricating a solid plastic part out of a photosensitive liquid polymer using a directed laser beam to solidify the polymer. The general setup for the process is illustrated in Figure; Part fabrication is accomplished as a series of layers, in which one layer is added onto the previous layer to gradually build the desired three-dimensional geometry. A part fabricated by STL is illustrated in Figure 3;

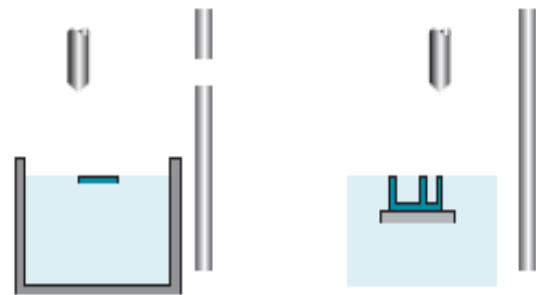

**Figure 3:** Stereolithography

The stereolithography apparatus consists of (1) A platform that can be moved vertically inside a vessel containing the photosensitive polymer. (2) A laser whose beam can be controlled in the x-y direction. At the start of the process, the platform is positioned vertically near the surface of the liquid photopolymer, and a laser beam is directed through a curing path that comprises an area corresponding to the base of the part.

This and subsequent curing paths are defined by the STI file preparing the control instructions described in the preceding. The action of the laser is to harden the photosensitive polymer where the beam strikes the liquid, forming a solid layer of plastic that adheres to the platform. When the initial layer is completed, the platform is lowered by a distance equal to the layer thickness, and a second layer is formed on top of the first by the laser, and so on.

Before each new layer is cured, a wiper blade is passed over the viscous liquid resin to ensure that its level is the same throughout the surface. Each

layer consists of its own area shape, so that the succession of layers, one on top of the previous, creates the solid part shape. Each layer is 0.076 to 0.50mm thick. Thinner layers provide better resolution and allow more intricate part shapes; but processing time is greater. Photopolymers are typically acrylic, although use of epoxy for STL has also been reported. The starting materials are liquid monomers.

Polymerization occurs upon exposure to ultraviolet light produced by helium-cadmium or argon ion lasers. Scan speeds of STL lasers typically range between 500 and 2500 mm/s. The time required to build the part by this layering process ranges from 1 hour for small parts of simple geometry up to several dozen hours for complex parts. Other factors that affect cycle time are scan speed and layer thickness.

In the case of stereolithography, the repositioning time involves lowering the worktable in preparation for the next layer to be fabricated. Other RP techniques require analogous repositioning steps between layers. The average scanning speed  $v$  must include any effects of interruptions in the scanning path.



**Figure 4:** A part produced by stereolithography

Photopolymers are typically acrylic, although use of epoxy for STL has also been reported. The starting materials are liquid monomers. Polymerization occurs upon exposure to ultraviolet light produced by helium-cadmium or argon ion lasers. Scan speeds of STL lasers typically range between 500 and 2500 mm/s.

After all of the layers have been formed, the photopolymer is about 95% cured. The piece is therefore “baked” in a fluorescent oven to completely solidify the polymer. Excess polymer is removed with alcohol, and light sanding is sometimes used to improve smoothness and appearance. Depending on its design and orientation, a part may contain overhanging features that have no means of support during the bottom-up approach used in stereolithography.

For example, in the part of Figure 4, if the lower half of the handle and the lower handlebar were eliminated, the upper portion of the handle would be unsupported during fabrication. In these cases, extra pillars or webs may need to be added to the part simply for support purposes. Otherwise, the overhangs may float away or otherwise distort the desired part geometry. These extra features must be trimmed away after the process is completed.

### 3.2. Solid Ground Curing

Like stereolithography, solid ground curing (SGC) works by curing a photosensitive polymer layer by layer to create a solid model based on CAD geometric data. Instead of using a scanning laser beam to accomplish the curing of a given layer, the entire layer is exposed to an ultraviolet light source through a mask that is positioned above the surface of the liquid polymer. The hardening process takes 2 to 3 seconds for each layer. SGC systems are sold under the name Solider system by Cubital Ltd. The starting data in SGC is similar to that used in stereolithography: a CAD geometric model of the part that has been sliced into layers.



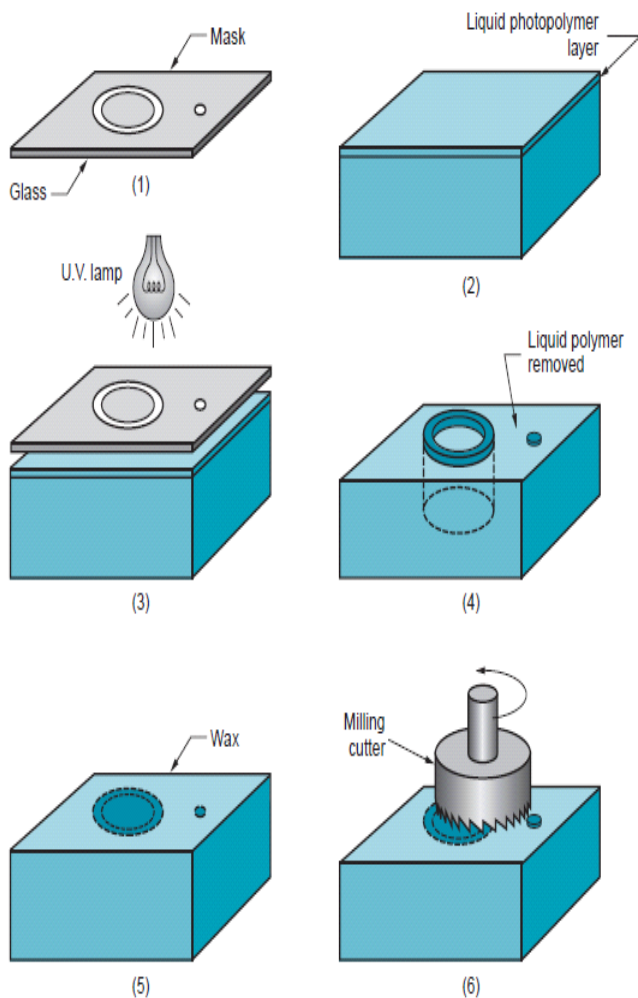

**Figure 5:** Solid ground curing process for each layer :

1. Masking Preparation
2. Applying Liquid Photopolymer Layer
3. Mask Positioning and Exposure of Layer
4. Uncured Polymer Removed from Surface
5. Wax Filling
6. Milling for Flatness and Thickness

For each layer, the step-by-step procedure in SGC is illustrated in Figure 5 and described here:

- (1) A mask is created on a glass plate by electrostatically charging a negative image of the layer onto the surface. The imaging technology is basically the same as that used in photocopiers.
- (2) A thin flat layer of liquid photopolymer is distributed over the surface of the work platform.
- (3) The mask is positioned above the liquid polymer surface and exposed by a high powered (e.g., 2000 W) ultraviolet lamp. The portions of the liquid polymer layer that are unprotected by the mask are solidified in about 2 seconds. The

shaded areas of the layer remain in the liquid state.

(4) The mask is removed, the glass plate is cleaned and made ready for a subsequent layer in step.

(5) The now-open areas of the layer are filled in with hot wax. When hardened, the wax acts to support overhanging sections of the part.

(6) When the wax has cooled and solidified, the polymer-wax surface is milled to form a flat layer of specified thickness, ready to receive the next application of liquid photopolymer.

### 3.3. Droplet Deposition Manufacturing

These systems operate by melting the starting material and shooting small droplets onto a previously formed layer. The liquid droplets cold weld to the surface to form a new layer. The deposition of droplets for each new layer is controlled by a moving x-y spray nozzle work head whose path is based on a cross section of a CAD geometric model that has been sliced into layers.

After each layer has been applied, the platform supporting the part is lowered a certain distance corresponding to the layer thickness, in preparation for the next layer. The term droplet deposition manufacturing (DDM) refers to the fact that small particles of work material are deposited as projectile droplets from the work head nozzle. Several commercial RP systems are based on this general operating principle, the differences being in the type of material that is deposited and the corresponding technique by which the work head operates to melt and apply the material.

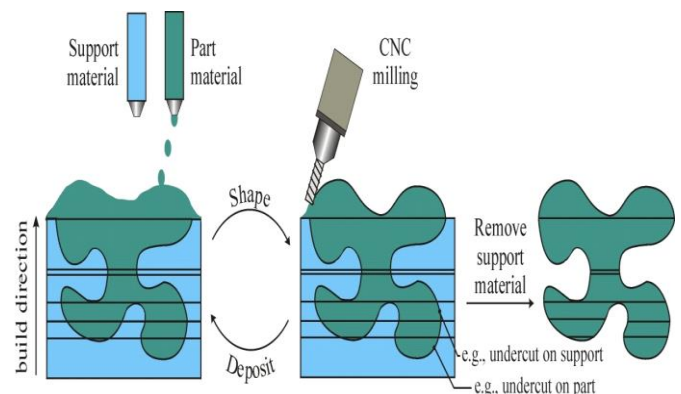

**Figure 6:** Droplet Deposition Manufacturing

An important criterion that must be satisfied by the starting material is that it be readily melted and solidified. Work materials used in DD Minclude wax and thermoplastics. Metals with low melting point, such as tin, zinc, lead, and aluminum, have also been tested. One of the more popular BPM systems is the Personal Modeler, available from BPM Technology, Inc. Wax is commonly used as the work material.

The ejector head operates using a piezoelectric oscillator that shoots droplets of wax at a rate of 10,000 to 15,000 per second. The droplets are of uniform size at about 0.076 mm (0.003 in) diameter, which flatten to about 0.05-mm (0.002-in) solidified thickness on impact against the existing part surface. After each layer has been deposited, the surface is milled or thermally smoothed to achieve accuracy in the z-direction. Layer thickness is about 0.09 mm (0.0035 in).

#### 4. Solid-Based Rapid Prototyping Systems

The common feature in these RP systems is that the starting material is solid. In this section we discuss two solid-based RP systems:

- (1) Laminated-object manufacturing.
- (2) Fused-deposition modeling.

##### 4.1. Laminated-Object Manufacturing

The principal company offering laminated-object manufacturing (LOM) systems is Helisys, Inc. Of interest is that much of the early research and development work on LOM was funded by National Science Foundation. The first commercial LOM unit was shipped in 1991.

Laminated-object manufacturing produces a solid physical model by stacking layers of sheet stock that are each cut to an outline corresponding to the cross-sectional shape of a CAD model that has been sliced into layers. The layers are bonded one on top of the previous one before cutting. After cutting, the excess material in the layer remains in place to support the part during building. Starting material in LOM can be virtually any material in sheet stock form, such as paper, plastic, cellulose, metals, or fiber-reinforced materials. Stock thickness is 0.05 to 0.50 mm (0.002 to 0.020 in).

In LOM, the sheet material is usually supplied with adhesive backing as rolls that are

spooled between two reels, as in Figure 7. Otherwise, the LOM process must include an adhesive coating step for each layer. The data preparation phase in LOM consists of slicing the geometric model using the STL file for the given part. The slicing function is accomplished by LOM Slice TM, the special software used in laminated-object manufacturing.

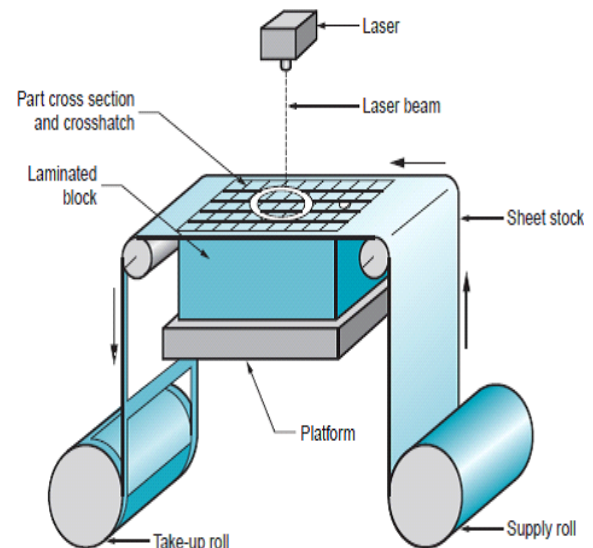

**Figure 7:** Laminated-object manufacturing

Slicing the STL model in LOM is performed after each layer has been physically completed and the vertical height of the part has been measured. This provides a feedback correction to account for the actual thickness of the sheet stock being used, a feature unavailable on most other RP systems. With reference to Figure 7, the LOM process for each layer can be described as follows, picking up the action with a sheet of stock in place and bonded to the previous stack:

(1) LOM Slice TM computes the cross-sectional perimeter of the STL model based on the measured height of the physical part at the current layer of completion.

(2) A laser beam is used to cut along the perimeter, as well as to crosshatch the exterior portions of the sheet for subsequent removal. The laser is typically a 25 or 50 W CO<sub>2</sub> laser. The cutting trajectory is controlled by means of an x-y positioning system. The cutting depth is controlled so that only the top layer is cut.

(3) The platform holding the stack is lowered, and the sheet stock is advanced between supply roll

and take-up spool for the next layer. The platform is then raised to a height consistent with the stock thickness and a heated roller moves across the new layer to bond it to the previous layer.

The height of the physical stack is measured in preparation for the next slicing computation by LOM Slice TM. When all of the layers are completed, the new part is separated from the excess external material using a hammer, putty knife, and wood carving tools. The part can then be sanded to smooth and blend the layer edges. A sealing application is recommended, using a urethane, epoxy, or other polymer spray to prevent moisture absorption and damage.

LOM part sizes can be relatively large among RP processes, with work volumes up to 800 mm-500 mm by 550 mm (32in-20in-22 in). More common work volumes are 380 mm-250 mm-350 mm (15in-10in -14in). Several low-cost systems based on the LOM build method are available.

#### 4.2. Fused-Deposition Modeling

Fused-deposition modeling (FDM) is an RP process in which a filament of wax or polymer is extruded onto the existing part surface from a work head to complete each new layer. The work head is controlled in the x-y plane during each layer and then moves up by a distance equal to one layer in the z-direction.

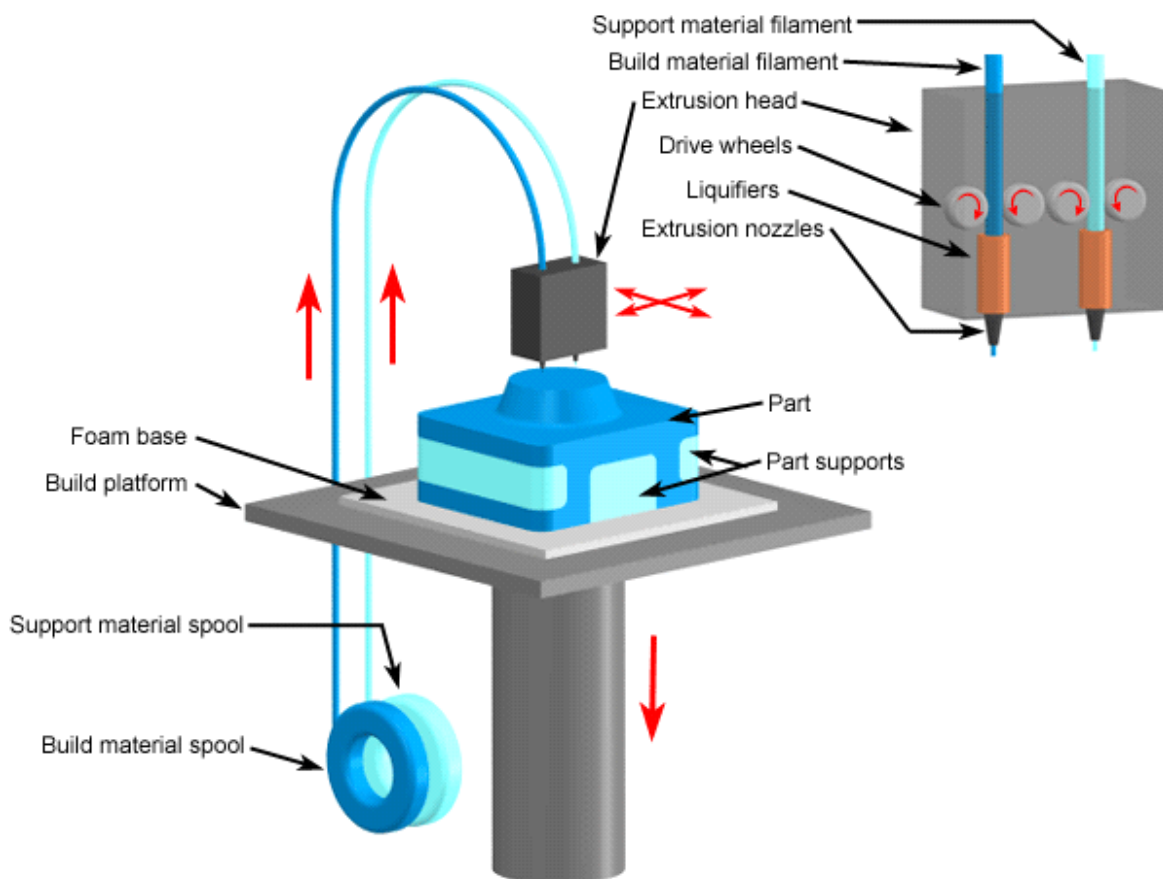

**Figure 8:** Fused Deposition Modelling

The starting material is a solid filament with typical diameter  $\frac{1}{4}$  1.25 mm (0.050 in) fed from a spool into the work head that heats the material to about (0.5C-1F) above its melting point before extruding it onto the part surface. The extrudate is

solidified and cold welded to the cooler part surface in about 0.1 second.

The part is fabricated from the base up, using a layer-by layer procedure similar to other RP systems. FDM was developed by Stratasys Inc., which sold its first machine in 1990. The starting

data is a CAD geometric model that is processed by Stratasys's software modules Quick Slice; and Support Work TM. Quick Slice; is used to slice the model into layers, and Support Work TM is used to generate any support structures that are required during the build process. If supports are needed, a dual extrusion head and a different material is used to create the supports. The second material is designed to readily be separated from the primary modeling material.

The slice thickness can be set anywhere from 0.05 to 0.75mm(0.002 to 0.030 in).About 400mmof filament material can be deposited per second by the extrusion work head in widths that can be set between 0.25 and 2.5 mm (0.010 to 0.100 in). Starting materials are wax and several polymers, including ABS, polyamide, polyethylene, and polypropylene. These materials are nontoxic,

allowing the FDM machine to be set up in an office environment.

## 5. POWDER-BASED RAPID PROTOTYPING SYSTEMS

The common feature of the RP technologies described in this section is that the starting material is powder. We discuss two RP systems in this category:

- (1) Selective laser.
- (2) Three-dimensional printing.

### 5.1. Selective Laser Sintering

Selective laser sintering (SLS) uses a moving laser beam to sinter heat-fusible powders in areas corresponding to the CAD geometric model one layer at a time to build the solid part. After each layer is completed, a new layer of loose powders is spread across the surface using a counter-rotating roller.

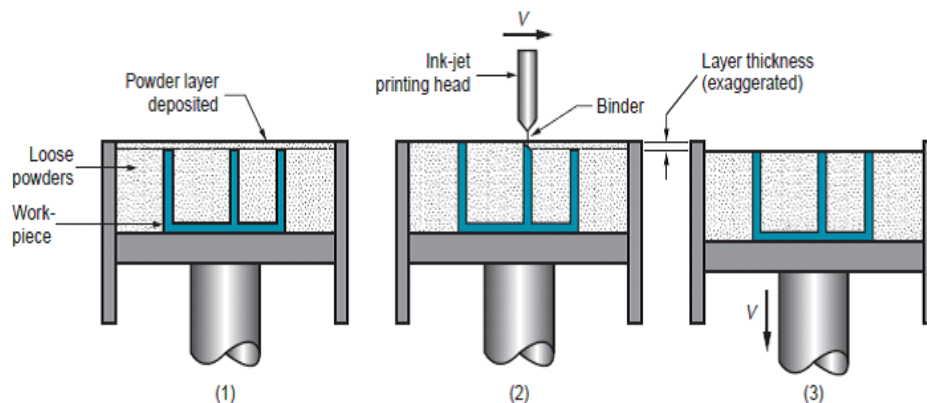

Figure 9: Selective Laser Sintering

The powders are preheated to just below their melting point to facilitate bonding and reduce distortion. Layer by layer, the powders are gradually bonded into a solid mass that forms the three-dimensional part geometry. In areas not sintered by the laser beam, the powders remain loose so they can be poured out of the completed part. Meanwhile, they serve to support the solid regions of the as fabrication proceeds. Layer thickness is 0.075 to 0.50 mm (0.003 to 0.020 in).

SLS was developed at the University of Texas (Austin) as an alternative to stereolithography, and SLS machines are currently marketed by DTM Corp. It is a more versatile process than stereolithography in terms of possible work

materials. Current materials used in selective laser sintering include polyvinylchloride, polycarbonate, polyester, polyurethane, ABS, nylon, and investment casting wax. These materials are less expensive than the photosensitive resins used in stereolithography. They are also nontoxic and can be sintered using low power (25 to 50W)CO<sub>2</sub> lasers. Metal and ceramic powders are also being used in SLS.

### 5.2. Three-Dimensional Printing

This RP technology was developed at Massachusetts Institute of Technology. Three-dimensional printing (3DP) builds the part in the usual layer-by-layer fashion using an ink-jet



printer to eject an adhesive bonding material onto successive layers of powders.

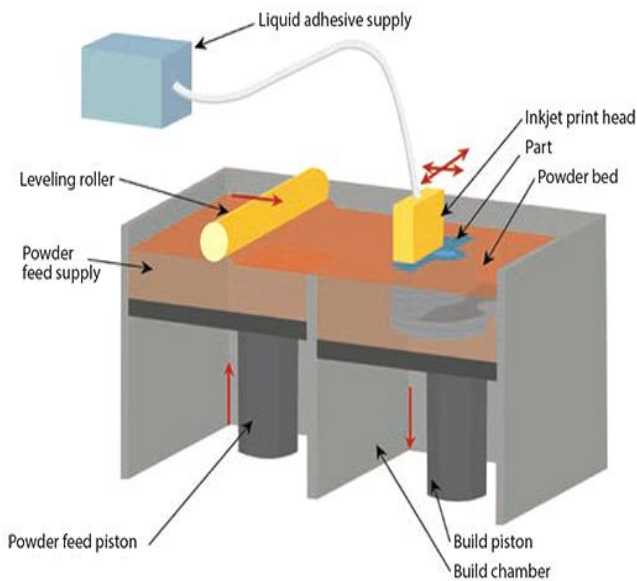

**Figure 10:** Three Dimensional Printing

The binder is deposited in areas corresponding to the cross sections of the solid part, as determined by slicing the CAD geometric model into layers. The binder holds the powders together to form the solid part, while the unbounded powders remain loose to be removed later. While the loose powders are in place during the build process, they provide support for overhanging and fragile features of the part. When the build process is completed, the part is heat treated to strengthen the bonding, followed by removal of the loose powders.

To further strengthen the part, a sintering step can be applied to bond the individual powders. The part is built on a platform whose level is controlled by a piston. Let us describe the process for one cross section with reference to Figure 8:

- (1) A layer of powder is spread on the existing part-in-process.
- (2) An ink-jet printing head moves across the surface, ejecting droplets of binder on those regions that are to become the solid part.
- (3) When the printing of the current layer is completed, the piston lowers the platform for the next layer.

Starting materials in 3DP are powders of ceramic, metal, or cermet, and binders that are polymeric or colloidal silica or silicon carbide. Typical layer thickness ranges from 0.10 to 0.18 mm (0.004 to

0.007 in). The ink-jet printing head moves across the layer at a speed of about 1.5 m/s (59 in/sec), with ejection of liquid binder determined during the sweep by raster scanning.

## 6. Applications of Rapid Prototyping

Applications of rapid prototyping can be classified into three categories:

- (1) Design.
- (2) Engineering analysis and planning.
- (3) Tooling and manufacturing.

### 6.1. Design

This was the initial application area for RP systems. Designers are able to confirm their design by building a real physical model in minimum time using rapid prototyping. The features and functions of the part can be communicated to others more easily using a physical model than by a paper drawing or displaying it on CAD system monitor.

Benefits to design attributed to rapid prototyping include:

- (1) Reduced lead times to produce prototype components.
- (2) Improved ability to visualize the part geometry because of its physical existence.
- (3) Earlier detection and reduction of design errors.
- (4) Increased capability to compute mass properties of components and assemblies.

### 6.2. Engineering Analysis and Planning

The existence of an RP-fabricated part allows for certain types of engineering analysis and planning activities to be accomplished that would be more difficult without the physical entity.

Some of the possibilities are

- (1) Comparison of different shapes and styles to optimize aesthetic appeal of the part.
- (2) Analysis of fluid flow through different orifice designs in valves fabricated by RP.
- (3) Wind tunnel testing of different streamline shapes using physical models created by RP.
- (4) Stress analysis of a physical model.
- (5) Fabrication of preproduction parts by RP as an aid in process planning and tool design.
- (6) Combining medical imaging technologies, such as magnetic resonance imaging (MRI), with

RP to create models for doctors in planning surgical procedures or fabricating prostheses or implants.

### 6.3. Tooling and Manufacturing

The trend in RP applications is toward its greater use in the fabrication of production tooling and for actual manufacture of parts. When RP is adopted to fabricate production tooling, the term rapid tool making (RTM) is often used. RTM applications divide into two approaches: indirect RTM method, in which a pattern is created by RP and the pattern is used to fabricate the tool, and direct RTM method, in which RP is used to make the tool itself.

#### 6.3.1. Examples of indirect RTM include:

- (1) Use of an RP fabricated part as the master in making a silicon rubber mold that is subsequently used as a production mold,
- (2) RP patterns to make the sand molds in sand casting
- (3) Fabrication of patterns of low-melting point materials (e.g., wax) in limited quantities for investment casting
- (4) Making electrodes for EDM.

#### 6.3.2. Examples of direct RTM include:

- (1) RP fabricated mold cavity inserts that can be sprayed with metal to produce injection molds for a limited quantity of production plastic parts.
- (2) 3D printing to create a die geometry in metallic powders followed by sintering and infiltration to complete the fabrication of the die.

#### 6.3.3. Examples of actual part production include:

- (1) Small batch sizes of plastic parts that could not be economically injection molded because of the high cost of the mold.
- (2) Parts with intricate internal geometries that could not be made using conventional technologies without assembly.
- (3) One of a kind parts such as bone replacements that must be made to correct size for each user.

Not all RP technologies can be used for all of these tooling and manufacturing examples. Interested readers should consult more complete

treatments of the RP technologies for specific details on these and other examples.

### 7. Problems with Rapid Prototyping

The principal problems with current RP technologies include:

- (1) Part accuracy.
- (2) Limited variety of materials.
- (3) Mechanical performance of the fabricated parts.

Several sources of error limit part accuracy in RP systems:

- (1) Mathematical.
- (2) Process related.
- (3) Material related.

#### 7.1. Mathematical

The mathematical errors include approximations of part surfaces used in RP data preparation and differences between the slicing thicknesses and actual layer thicknesses in the physical part. The latter differences result in z-axis dimensional errors. An inherent limitation in the physical part is the steps between layers, especially as layer thickness is increased, resulting in a staircase appearance for sloping part surfaces.

#### 7.2. Process Related

The process related errors are those that result from the particular part building technology used in the RP system. These errors degrade the shape of each layer as well as the registration between adjacent layers. Process errors can also affect the z-axis dimension. Finally, material related errors include shrinkage and distortion. An allowance for shrinkage can be made by enlarging the CAD model of the part based on previous experience with the process and materials.

#### 7.3. Material Related

As the current rapid prototyping systems are limited in the variety of materials they can process. For example, the most common RP technology, stereolithography, is limited to photosensitive polymers. In general, the materials used in RP systems are not as strong as the production part materials that will be used in the actual product. This limits the mechanical performance of the prototypes and the amount of

realistic testing that can be done to verify the design during product development.

Rapid prototyping technologies are for small series and complex plans, these techniques are often the best manufacturing processes available. They are not a solution to part fabrication problem. After GNG technology and injection molding are economical, widely understood, available, and offer wide material selection. Because these are non-prototyping applications, rapid prototyping is often referred to as solid freeform fabrication or layered manufacturing. The rapid prototyping are the technologies that have been adapted from the conventional manufacturing and assembly operations or developed from scratch to serve the special functions or needs of designers and manufacturers.

### 8. Conclusion

The use of Rapid Prototyping technologies is essential in any design fields. Although it was conceived as an medical application, arts, architecture applications, the mechanical field can also take benefit from this technology. It gives the mechanical engineer, the possibility to visualize those complex shapes not easily seen or understood on connectional drawings, and touch them to verify the shape. It can be used to in early design stages to build a conceptual model or in

later stages when details are needed. Complex shapes can be obtained using Surface and solid modeling CAD software, and then build the physical model. In a few hours the model can be built easily, in a similar way as a 2D drawing is plotted. In a short time, rapid prototyping will become a technology that will be used routinely by many design engineers in conjunction with the traditional existing ways of creating scale models of mechanical parts.

### 9. References

1. Chua. C.k., Leong, K.F. (2000), "Rapid Prototyping: Principles and Applications in Manufacturing", World Scientific.
2. B. Sushila, K. Karthik, P. Radhakrishanan, "Rapid Tooling for casting – A case study on application of Rapid Prototyping Processes", Indian Foundry Journal, 11,213-216.
3. Dr. Khalid Abd. Elghany, "Rapid Prototyping and Additive Manufacturing in Egypt", Central Metallurgical Research and Development Institute (CMRDI).
4. Wlodzimierz Przybylski, Stefan Dzionk, "Impeller Pump Development Using Rapid Prototyping Methods", Advances in Manufacturing Science and Technology, Vol. 35, No. 1, 2011.