

# The Influence of Work Environment, Discipline and Work Ethic on Employee Performance

## (Case study: PTJaya Masawan Putra Sejahtera)

Eko Wijaya Putra Utama<sup>1</sup>, Muhammad Wadud<sup>2</sup>

<sup>1,2</sup>Master of Management Study Program, Postgraduate, Indo Global Mandiri University, Indonesia

Email : 2021502005@students.uigm.ac.id<sup>1</sup>, wadud@uigm.ac.id<sup>2</sup>

### Abstract:

The aim of the research is to find out whether the work environment, work discipline and work ethic influence the performance of employees at PT Jaya Masawan Putra Sejahtera, Lemabang Head Office, Palembang City. This type of research is quantitative. The population was 200 people with sampling using saturated samples. Data analysis techniques use descriptive statistical tests, instrument quality tests, classical assumption tests, multiple linear regression analysis and hypothesis testing. The results of the research state that the work environment influences the performance of PT JMPS Lemabang Head Office employees, work discipline influences the performance of PT JMPS Lemabang Head Office employees and work ethic influences the performance of PT Jaya Masawan Putra Sejahtera Lemabang Head Office Palembang City employees and together the work environment, work discipline and work ethic influence the performance of PT JMPS Lemabang Head Office employees.

**Keywords:** Work Environment, Work Discipline, Work Ethic, Employee Performance

### 1. Background

Companies are generally founded with the aim of making a profit through the sale of products or services. In achieving these sales targets, companies need planning that is in accordance with the vision and mission. One important factor in achieving this is human resources (HR). Quality human resources according to company needs are needed to win the competition. Therefore, human resource management (HRDM) has an important role in determining the quality of human resources and appropriate position placement.

PT Jaya Masawan Putra Sejahtera (JMPS / JM Group) is one of the largest retail companies in Palembang. In carrying out its operational activities, PT JMPS requires employees who have good performance. Performance is the work achievement produced by employees in accordance with the roles and tasks they carry out in the agency (Gulo, 2020:2). Employees must be able to realize the importance of the roles and tasks they carry out as well as possible. To achieve maximum performance, all personal abilities are mobilized in accordance with established instructions or performance achievement standards (Riwukore & Habaora, 2022). Improving employee performance is a challenge for human resource management, because success in achieving company goals and survival depends on the quality of human resources (Putu et al., 2022).

Employee performance in carrying out company operational activities is very important. Factors such as work environment and work discipline influence employee performance. A comfortable and conducive work environment can improve employee performance, while a lack of discipline can reduce performance.

There are several factors that influence employee performance, such as the work environment. The work environment is everything that is around the employee while working, both physical and non-physical, which can influence him in carrying out his daily tasks and work Munardi et al., (2021). For the physical work environment, the company must prepare an adequate environment such as a comfortable, cool environment, light that is not dazzling, safe and clean. Having a comfortable work environment will make

employees happy and will increase their performance.

Creating a good work environment will greatly determine the success of achieving organizational goals (Yantika et al., 2018). If employees like the environment where they work, then the employee will feel comfortable at work and carry out their activities optimally. So, working time will be used more effectively. This is in line with research conducted by Mashuri et al., (2019) which states that work environment variables influence employee performance.

If the work environment is not good, it can cause a lack of encouragement and even passion for work, which can be a factor in reducing employee performance (Susanti & Mardika, 2021). "A good work environment can support the implementation of work so that employees have the enthusiasm to work and improve employee performance" (Sugiarti, 2021). Therefore, the importance of this work environment must be of concern to companies, because it has a direct impact on employees.

Discipline has the aim that every employee is obliged to obey and comply with the rules. Enforcing discipline is something that must be implemented by a company which is assigned regulations that must be obeyed by all employees without exception (Soejarminto & Hidayat, 2022). Work discipline is very important in an effort to ensure the maintenance of order and the smooth implementation of each task. Discipline makes employees work more focused in accordance with the company's wishes and prevents employees from being punished or fined. Employees comply with the regulations set by the company and have high discipline, which will create a more conducive company atmosphere so that it will have a positive impact on company activities (Khaeruman et al., 2021). This is in line with research conducted by Meilinda et al., (2022) which states that the work ethic variable influences employee performance.

Based on observations at PT JMPS, several problems were found related to the work environment and employee work discipline. Some employees do not comply with company rules, such as carrying and using cellphones while working, coming to work not according to procedures, being absent without explanation, and often being late. Apart from that, some employees also seem unfocused at work and often chat, which can interfere with productivity.

Work ethic is also an important factor in improving employee performance. Employees with a high work ethic tend to be more committed to their work and achieve optimal results.

Work ethic is positive behavior possessed by an individual that is motivating, positive beliefs that encourage enthusiasm to work or act optimally. "work ethics describes the extent to which an employee sides with a particular organization and its goals, and intends to maintain membership in that organization" (Juliati, 2021). Employees who have a high work ethic can certainly improve their performance because these employees do not give up easily and do what they do seriously. This is in line with research conducted by Grace et al., (2021) which states that the work ethic variable influences the performance of PT employees. Karya Bhakti Manunggal.

A good work ethic can certainly have an impact not only on individuals but can also have a positive impact on other employees. If employees have a high work ethic, then employees will enjoy their work happily, thus having a positive impact on improving employee performance (Ningrat & Yudana, 2020).

From the results of observations, several employees at PT JMPS still show a poor work ethic, such as not checking receipts properly, providing information to superiors late, and lacking concentration in serving customers.

Differences in research results from several sources show the complexity of factors that influence employee performance. (Arifuddin, 2023)(Mashuri et al., 2019)(Yasdianto et al., 2020) However, based on observations at PT JMPS, the work environment is lacking conduciveness and lack of work discipline and work ethic from some employees is a problem that needs to be paid attention to and corrected by the company.

## **2. Literature Review**

### **Management**

Management comes from English, namely management (noun), with the verb to manage, which can be interpreted as managing. Based on existing literature, management can be seen from three definitions, such as management as a process, management as a human collectivity, management as a science. In management, the father of management is known as Frederick Winslow Taylor.

According to (Firmansyah M.A & Mahardika B.W, 2018) management is a series of activities starting from

the beginning of carrying out activities until the end of achieving the activity goals. According to (Yustini & Yuliza, 2021) management is the art of influencing other people to work together and utilize existing technology in order to achieve organizational goals so that the company's goals are achieved by maximizing the resources it has. Management as a 'process' is a systematic way to carry out an activity/work without considering the existence of special abilities or skills and must carry out certain interrelated activities to achieve the goals that have been set/desired (Suhardi, 2018).

Management is a science that carries out the process of achieving goals by utilizing existing resources within the organization efficiently and effectively (Imbron & Pamungkas, 2021). According to the statement above, it can be synthesized that management is the art and science of systematically organizing a group of people aimed at achieving predetermined goals.

### **Work environment**

The work environment should be made as comfortable as possible, if employees are comfortable in their workplace, of course they can carry out their activities in the company with satisfactory results. According to Burhannudin et al., (2019) stated that the work environment is an activity environment where employees carry out work that can influence the achievement of organizational goals and create comfort in carrying out their tasks.

According to Munardi et al., (2021) stated that the work environment is everything that is around the employee while working, both physical and non-physical, which can influence him in carrying out his daily tasks and work. The work environment is the social, psychological and physical life within a company that influences workers in carrying out their duties (Maryani et al., 2022).

Therefore, this work environment must be really paid attention to. The work environment is the situation or circumstances around employees that influence them in carrying out the tasks assigned to them (Julita, 2020). Based on the results above, it can be synthesized that the work environment is all the components contained in the workplace that influence employees in carrying out their duties.

### **Work Discipline**

Discipline comes from the root word "*discipline*" which means learning. Discipline is a direction to train and shape someone to do something better. Discipline is very important for an organization or company because the better the employee's discipline, the better the company will achieve performance. According to Khaeruman et al., (2021:23) stated that work discipline is an attitude, behavior and actions that are in accordance with written and unwritten regulations, and if they are violated there will be sanctions for the violation.

According to Tajudin & Supriadi (2021) work discipline is an attitude of awareness and willingness of a person or group in an organization, an attitude of employee obedience and loyalty to written/unwritten regulations which is reflected in the form of behavior and actions at the company to achieve a certain goal. Every employee must be aware that while they are in the company's work environment, employees must have high discipline. Apart from that, discipline has an important role in the company.

Work discipline is a mental attitude possessed by employees in respecting and complying with existing regulations in the organization where they work, which is based on responsibility, not because of compulsion, so that they can change their behavior to be better than before (Tsauri, 2013: 130).

From all the definitions according to the experts above, the author synthesizes that work discipline is an attitude or behavior that employees have consciously following all the rules contained in a company. If discipline is not implemented, employees will receive sanctions from the company.

### **Work ethic**

Ethos in Indonesian comes from the Greek word ethos which means "character used to describe guiding beliefs or guiding standards/principles that characterize a national community or ideology (Ginting, 2016:2).

According to Simanjuntak (2020) work ethic is a set of positive work behaviors that are rooted in strong cooperation, fundamental beliefs, accompanied by total commitment to an integral work paradigm. Every employee must have a high work ethic because companies need employees who are hard workers and have high commitment in every job so that it is easy for the organization to develop and win business competition. According to Badriati (2021:6) states that work ethic can also take the form of assessment movements and

have evaluative movements for each individual and group. According to Butarbutar et al., (2021) stated that work ethic is a person's attitude and behavior that describes personal character that can have an influence on himself which can convince him to be able to make a good contribution to himself and to other parties. Based on the description above, it can be concluded that work ethic is positive behavior possessed by individuals that is motivating, positive beliefs that encourage enthusiasm to work or act at optimal performance.

**Performance**

According to Budiyanto & Mochklas (2020:10) states that performance is a description of the level of achievement of implementing an activity/program/policy in realizing the organization's targets, goals, vision and mission legally, without breaking the law and in accordance with morals and ethics, as stated in formulation of strategic planning (strategic planning) of the organization concerned. Performance is an action that consists of several elements and is not an instant result (Huseno, 2016: 88).

According to Hasyim & Pasaribu (2021), performance is a measure of both the quantity and quality of an individual's work results which can be used to compare assignments and dependents. With good performance, of course employees can complete their work well.

Based on the description above, it can be concluded that performance is the achievement or result of processes carried out by employees based on standards set by a company.

**3. Research Methods**

**Thinking Framework**

In this section, a conceptual framework or model of thinking will be proposed which will serve as a model for empirical research and function as a guide in testing hypotheses. This diagram shows the existence of a causal relationship between the work environment, work discipline and work ethic on employee performance.

A conducive work environment between superiors and subordinates or fellow co-workers will have a good impact. Apart from that, working environmental conditions caused by physical factors such as facilities used during work will also support employee performance.

Work discipline is an attitude that employees must have because it is a concern in every job carried out by each employee in order to improve performance. Discipline can also prevent employees from being punished. Every employee must also have a work ethic with a high work ethic that can support their performance and bring the company to achieve the company's desired goals in accordance with the vision and mission. The rationale for this research is as follows:

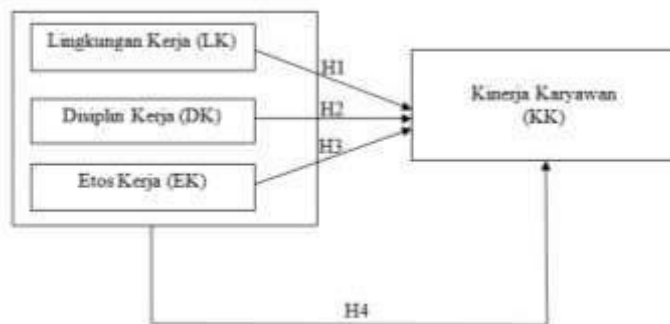

Figure 1 Thinking Framework

**Hypothesis**

The research hypothesis is an initial guess or temporary conclusion about the relationship between the influence of the independent variable on the dependent variable. Based on the problem formulation, objectives, theory, previous research, and framework of thought, the hypothesis in this research is:

In various literature in human resource management research, there is an influence of the work environment on employee performance (Rotto et al., 2022); (Firdausyi & Kasmari, 2022); (Dewi & Marpaung, 2023). According to Yantika et al., (2018), creating a good work environment will greatly determine the success of achieving organizational goals.

Work discipline is also an aspect that needs to be considered, because with good work discipline the employee performance will be better. Without good discipline it will be difficult for the company to achieve maximum results (Prakoso et al., 2020). In other research, there are also those who say that discipline has no effect on employee performance (Adela Putri et al., 2022). Other research identifies that there is an influence between

discipline on employee performance (Map & Baeha, 2020); (Sunarno, 2021); (Handayani & Oktapiani, 2021); (Firdausyi & Kasmari, 2022); (Dewi & Marpaung, 2023).

Work ethic can be said to be important because it is a positive attitude that employees have to encourage performance. For this reason, employees need a high work ethic to support company goals. To improve employee performance, a good work ethic is needed, every employee should have a good work ethic because every company requires hard work and high commitment from every employee (Suryadi & Karyono, 2022). If it is related to human life situations, a high work ethic will be used as an absolute requirement, which is cultivated in life (Saputra et al., 2019). therefore, there is an influence of work ethic on performance according to research conducted by (Firdausyi & Kasmari, 2022); (Risma & Arwiah, 2022); (Nabilla et al., 2022); (Olivia et al., 2023); by (Aqsariyanti et al., 2019).

So the hypothesis of this research is:

H1: The work environment influences employee performance at PT Jaya Masawan Putra Sejahtera, Lemabang Head Office, Palembang City.

H2: Work Discipline Influences the Performance of PT Jaya Masawan Putra Sejahtera Employees, Lemabang Head Office, Palembang City.

H3: Work Ethic Influences the Performance of PT Jaya Masawan Putra Sejahtera Head Office Employees

The analysis technique used in this research is quantitative data analysis technique. These analysis techniques include descriptive statistical tests, instruments, classical assumption tests, multiple linear regression analysis tests and hypothesis testing

#### 4. Results

Research was conducted at PT. Jaya Masawan Putra Sejahtera Lemabang Head Office, Palembang City, located at Jl. R. E. Martadinata No. 1909, Sei Buah, Kec. Ilir Tim. II, Palembang City, South Sumatra 30163. The variables in this research are Work Environment (LK), Work Discipline (DK), Work Ethic (EK) and Employee Performance (KK).

##### Number of respondents

The number of respondents used was 200 people with the following details:

**Table 1: Frequency of Respondents Based on Work Department**

No	Respondent	Amount	Percentage (%)
1	Office	51	25,5%
2	Shop	149	74,5%
	Total	200	100%

Source: Processed data, 2023

Based on Table 1, it is known that the number of respondents in the office work department was 51 people or 25.5%, while in the shop department there were 149 people or 74.5%. From the results of respondents' answers, it is known that the largest number of respondents were in the shop section, namely 149 people or 74.5%.

The classification of respondents based on gender is as follows:

**Table 2: Frequency of Respondents Based on Gender**

No	Respondent	Amount	Percentage (%)
1	Woman	147	73,5%
2	Man	53	26,5%

	Total	200	100%
--	-------	-----	------

Source: Processed data, 2023

Based on Table 2, it is known that the number of respondents with female gender was 147 people or 73.5%, while there were 53 male respondents or 26.5%. From the results of the respondents' answers, it is known that the largest number of respondents were female, namely 147 people or 73.5%.

### Validity and Reliability Test of Research Instruments

A questionnaire is said to be valid if it is able to measure the value of the variable being studied. The conditions for an item are said to be valid if Rcount is greater than Rtable, conversely an item is said to be invalid if Rcount is smaller than Rtable. Determination of the R table value is seen with  $df = n-2$  or Sig value  $< 0.05$ . Reliability testing is carried out to measure the extent to which the results of a measurement can be trusted. A questionnaire is reliable or reliable if a person's answers to statements are consistent or stable over time. Reliability testing uses methods *Cronbach Alpha*. A statement is said to be reliable if it provides value *cronbach alpha*  $> 0.6$ . The results of testing the validity and reality of the questionnaire instrument are shown in Table 3 below

**Table 3: Reliability Validity Test Results**

Variable	<i>Cronbach's Alpha</i>	Results	Sig	Results
Work Environment (LK)	0,729	Reliable	0.0000	Valid
Work Discipline (DK)	0,680	Reliable	0.0000	Valid
Ethos Kerja (EK)	0,670	Reliable	0.0000	Valid
ee Performance (KK)	0,736	Reliable	0.0000	Valid

Source: Processed data, 2023.

If value *Cronbach's Alpha* greater than 0.6, then the research questionnaire is reliable and if the significance of Sig  $< 0.05$  then the instrument is valid

### Normality Test Results

Normality testing is used to test whether the distribution is normal or the residual has a normal distribution or not. The level of significance used  $\alpha = 0.05$ . If the probability value  $p \geq 0.05$ , then the normality assumption is met. If the probability  $< 0.05$ , then the normality assumption is not met

**Table 4 Normality Test Results**

<i>Unstandardized Residual</i> <i>Asymp. Sig. (2-tailed)</i>	Information
	0,200 Normally Distributed Data

Source: Processed data, 2023.

Based on table 4 above, the value is known *Asymp.Sig. (2-tailed)* of 0.200 is greater than 0.05 so it can be stated that the residuals in this study are normally distributed.

### Multicollinearity Test Results

This test was carried out to test whether the regression model found a correlation between the independent variables. If there is a correlation then it is called a multicollinearity relationship. A good regression model is free from multicollinearity. Testing for multicollinearity can be done by looking at the Variance Inflating Factor (VIF) value. If the VIF value is  $> 10$  then multicollinearity occurs in the regression model.

**Table 5: Multicollinearity Test Results**

Model	<i>Tolerance</i>	<i>Co</i> <i>llinearity</i> <i>Stati</i> <i>VIF</i>	<i>stic</i> <i>Information</i>
Environment (LK)	0,675	1,481	Multicollinearity does not occur

Work Discipline (DK)	0,920	1,087	Multicollinearity does not occur
Ethos Kerja (EK)	0,704	1,420	Multicollinearity does not occur

Source: Processed data, 2023.

Table 5 shows that the VIF value of Work Environment is 1.481, the VIF value of Work Discipline is 1.087 and the VIF value of Work Ethic is 1.420. Because all VIF values are <10, it is concluded that there is no multicollinearity.

### Heteroscedasticity Test Results

This test examines the differences in residual variance from another observation period, or describes the relationship between the predicted value and the residual value. Data is declared not heteroscedastic if the significance value is greater than 0.05.

**Table 6: Heteroscedasticity Test Results**

Variable	Significance	Information
Work Environment (LK)	0,361	Not Heteroscedasticity
Work Discipline (DK)	0,758	Not Heteroscedasticity
Ethos Kerja (EK)	0,248	Not Heteroscedasticity

Source: Processed data, 2023.

Based on Table 6, all values are known. The Glejser of each independent variable is above 0.05, so it is concluded that heteroscedasticity does not occur.

### Results of Multiple Linear Regression Analysis

The data analysis technique in this research is a multiple regression model. Multiple regression aims to measure the strength of the relationship between the dependent variable and the independent variable.

**Table 7: Multiple Linear Regression Analysis Test Results**

Model	B	t	Significance
Constant	1,494	0,518	0,605
Work Environment (LK)	0,612	8,280	0,000
Work Discipline (DK)	0,195	2,630	0,009
Ethos Kerja (EK)	0,602	7,244	0,000

Source: Processed data, 2023.

Based on Table 7, the following multiple linear regression equation is obtained.

$$Y = 1,494 + 0,612LK + 0,195DK + 0,602EK + e$$

### t Test Results

The t test is carried out to see whether each independent variable (X) influences the dependent variable (Y). This test is used to find out whether the hypothesis will be accepted or rejected. The condition is that if the significant value is > 0.05, the hypothesis is rejected and if the significant value is ≤ 0.05, the hypothesis is accepted. Apart from comparing themselves. with level of significant 5% and t calculated with t table in this study is 1.97208. This value can be seen from the t distribution table, degree of freedom (df) = t – table, t = (200-3)/t = (0.05:197) = 1.97208, with a significance of 0.05.

**Table 8: t Test Results**

Work Environment (X <sub>1</sub> )	8,280	0,000	H1 is accepted
------------------------------------	-------	-------	----------------

Work Discipline ( $X_2$ )	2,630	0,009	H2 is accepted
Work Ethic ( $X_3$ )	7,244	0,000	H3 is accepted

Source: Processed data, 2023.

Based on the calculation results, it is known that  $t$  calculated from the Work Environment is  $8.280 > t_{table} = 1.97208$  and  $Sig.$  is  $0.000$ , namely  $< 0.05$  significance level. So the work environment has a significant effect on employee performance. This means that the physical work environment such as work facilities and tools, temperature, lighting, size of the workplace and non-physical work environment such as the relationship between superiors and subordinates, relationships between co-workers in the same division or different divisions have been implemented and are felt to be good so that the work environment influence the performance of employees of PT Jaya Masawan Putra, Lemabang Head Office, Palembang City.

Based on the calculation results, it is known that  $t$  calculated from work discipline is  $2.630 > t_{table} = 1.97208$  and  $Sig.$  is  $0.009$ , namely  $< 0.05$  significance level. So work discipline has a significant effect on employee performance. This means that work discipline such as coming and going home at the appointed time, obeying the rules, using equipment and uniforms according to the rules, following directions from superiors, volunteering to do work well, being responsible for the facilities and infrastructure used and receiving sanctions if you make a mistake, has an impact on employee performance of PT Jaya Masawan Putra, Lemabang Head Office, Palembang City. This is in accordance with the rules set by the company, for example being late consecutively within a certain period will be subject to sanctions or a warning letter and also various other types of violations, for example carrying a cellphone and playing while working, will also be subject to a warning letter.

Based on the calculation results, it is known that  $t$  calculated from Work Ethic is  $7.244 > t_{table} = 1.97208$  and  $Sig.$  is  $0.000$ , namely  $< 0.05$  significance level. This means that work ethic influences employee performance. This means that work ethic such as establishing team relationships, being strong in working, working with enthusiasm, being trustworthy in carrying out tasks, working when health is declining, being honest in carrying out work has an influence on the performance of employees of PT Jaya Masawan Putra, Lemabang Head Office, Palembang City. This is in accordance with the values instilled in every employee regarding LOJUPAS as company culture.

### F Test Results

The F test was carried out to determine whether the independent variables, namely, work environment, work discipline and work ethic, had a significant effect on the dependent variable, namely employee performance at the Lemabang Head Office, Palembang City.

**Table 9: F Test Results**

<i>F Statistic</i>	<i>Significance</i>	<i>Information</i>
100,800	0,000	Accepted

Source: Processed data, 2023.

Based on table 9 above, the  $F$  of  $100.800$  is greater than the  $F_{table}$ , namely  $2.65$  and the significance value of  $0.000$  is smaller than  $0.05$ . This means that the Work Environment, Work Discipline, Work Ethic together or simultaneously have a significant effect on the Employee Performance of PT Jaya Masawan Putra Sejahtera, Lemabang Head Office, Palembang City.

### Coefficient of Determination Test Results

Coefficient of determination ( $R^2$ ) is a value (proportion value) that measures the ability of the independent variables used in the regression equation to explain variations in the dependent variable.

**Table 10: Coefficient of Determination Test Results**

<i>Information</i>	<i>R Square (<math>R^2</math>)</i>
LK, DK and EK	0,607

Source: Processed data, 2023.



Based on Table 9, it is known that the coefficient of determination ( $R^2$ ) is 0.607 or 60.7%. This value shows that employee performance at PT Jaya Masawan Putra Sejahtera Lemabang Head Office, Palembang City is influenced by the Work Environment, Work Discipline and Work Ethic. Meanwhile, 39.3% was influenced by other variables not included in this research model.

## 5. Discussion

The test results show that the work environment has a positive and significant effect on employee performance at PT Jaya Masawan Putra Sejahtera, Lemabang Head Office, Palembang City. This shows that the work environment has a significant influence on employee performance. This conclusion is in line with empirical theory and shows that a good work environment makes employees feel comfortable and happy working at the company.

The results of this research are in line with research which states that there is an influence between the work environment on employee performance carried out by (Mashuri et al., 2019); (Arum et al., 2023); (Firdausyi & Kasmari, 2022); (Rotto et al., 2022); (Dewi & Marpaung, 2023).

Based on the results of descriptive statistics on the Work Environment (LK), the dominant indicator of the Work Environment (LK) variable is LK5, namely having a good working relationship between superiors and subordinates with a value of 4.74. The lowest indicator is LK6, namely, having good working relationships between colleagues in the same division with a value of 4.47.

The Influence of Work Discipline on Performance shows that work discipline influences the performance of employees of PT Jaya Masawan Putra Sejahtera, Lemabang Head Office, Palembang City. This is shown in the calculated t value of work discipline which is  $2.630 > t_{table} = 1.97208$  and *Say.* is 0.009, namely  $< 0.05$  significance level. Based on the opinion of Farida & Hartono (2016:43) it is stated that the aim of employee work discipline is to achieve an attitude of behavior and actions that are in accordance with regulations and take the initiative to take necessary actions with the desired goals which can lead to good performance for the company. According to Tsauri (2013:138), the factors that influence performance also state that work discipline is included in the factors that influence employee performance. Apart from that, according to W Enny (2019:115) states that employee performance is also influenced by work discipline.

Based on previous research, this is in line with research which states that there is an influence between work discipline on employee performance based on research conducted by (Hidayati et al., 2019); (Firdausyi & Kasmari, 2022); (Map & Baeha, 2020); (Sunarno, 2021); (Handayani & Oktapiani, 2021).

Based on the results of descriptive statistics, the work discipline variable, the DK1 indicator, has the highest value, namely 4.83, namely on the question of attending and leaving at the specified time. This shows that office and shop employees have come to work according to the time determined by the company. The value with the lowest indicator in the DK6 indicator is responsibility for the facilities and infrastructure that I use with a value of 4.62. This shows that the employee is responsible for the damage done by the employee.

The test results show that work ethic influences the performance of employees of PT Jaya Masawan Putra Sejahtera, Lemabang Head Office, Palembang City. This is shown in the calculated t value of Work Ethic which is  $7.244 > t_{table} = 1.97208$  and *Say.* is 0.000, namely  $< 0.05$  significance level. This shows that the hypothesis has been successfully confirmed and is in line with empirical theory. This shows that according to respondents, employees' Work Ethic (EK) is well possessed by employees of PT Jaya Masawan Putra Sejahtera, Lemabang Head Office, Palembang City.

According to Komala (2019), work ethic characteristics such as addiction to time, sincerity, honesty, commitment and determination have an impact on performance because these positive things can bring a good atmosphere in the company. Meanwhile, according to Badriati (2021:6), work ethic has a number of characteristics that become an identity, such as interpersonal skills, initiative, reliability and can encourage employees to further improve their performance.

This is directly proportional to the results of research which suggests that there is an influence of work ethic on employee performance (Yantika et al., 2018); (Arum et al., 2023); (Firdausyi & Kasmari, 2022); (Risma & Arwiah, 2022); (Nabilla et al., 2022); (Olivia et al., 2023); (Aqsariyanti et al., 2019). There is an opinion which says that "*work ethic describes the extent to which an employee sides with a particular organization and its goals, and intends to maintain membership in that organization*" (Juliati, 2021). If employees have a high work ethic, then employees will enjoy their work happily, thus having a positive impact on improving employee performance (Ningrat & Yudana, 2020).

In the descriptive statistics, it can be seen that the largest value is found in the EK1 variable, namely

establishing collaborative relationships with other colleagues to make work more successful with a value of 4.69. This shows that employees can collaborate with colleagues to achieve good results from a job. For example, shop employees coordinate when a consumer asks whether the stock of goods in the warehouse is available. The lowest indicator with a value of 4.33 on the EK5 indicator is that I still want to work when my health declines. This proves that when employees are sick they still want to work. for example, office employees, because maybe the work has been divided according to *job desk* respectively, if you don't come in, the work will certainly pile up.

The test results show that the work environment, work discipline and work ethic simultaneously influence the performance of employees of PT Jaya Masawan Putra Sejahtera, Lemabang Head Office, Palembang City. This is shown by the results obtained from the F value of 100.800 which is greater than the F table of 2.65 and the significance value of 0.000 is smaller than 0.05.

Based on the above, it shows that the work environment at PT JMPS Lemabang Head Office, Palembang City has been well created with various facilities and work tools, temperature, lighting, size of the workplace and non-physical work environment such as relationships between superiors and subordinates, relationships between co-workers. in the same division or different divisions it has been felt to be good so that the work environment influences the performance of PT JMPS employees, Lemabang Head Office, Palembang City. Work facilities are also supported by lifts and *cell phone* from companies that can be used, for the relationship between superiors and subordinates, PT JMPS always holds competitions such as August 17 with employees to strengthen ties between all members of PT JMPS Lemabang Head Office.

Work discipline at PT JMPS Lemabang Head Office, Palembang City has been felt to be good because employees have arrived and gone home at the appointed time, obeyed the rules, used equipment and uniforms according to the rules, followed directions from superiors, volunteered to do their work well, were responsible for facilities and the infrastructure used so that they have the courage to accept sanctions if they make a mistake. For changing work hours, sales assistants are present on time according to the distribution *shift*, for *shift* first at 10:00-17:30 and for *shift* two 13:00-22:00. The office section works from 08:20-17:30.

Work Ethic of employees of PT JMPS Lemabang Head Office, employees establish team relationships for satisfactory work results, strong will in work, work with enthusiasm, can be trusted in carrying out their duties, work when health is declining, honesty in carrying out work influences the performance of PT employees JMPS Lemabang Head Office, Palembang City. This is in accordance with the values instilled in every employee regarding LOJUPAS as company culture.

The work ethic of store employees is that store employees help consumers find clothes/shoes/pants/other necessities according to the consumer's size/request, through this there is coordination between one co-worker and another to check stock availability. Shop employees are also quick to provide information when asked which part of the display case the item the consumer is looking for is located. Office employees always complete their work on time, otherwise their work will pile up and of course the workload will increase.

The above shows that according to respondents they have done work according to targets, worked according to company standards, met the quantity of work, completed work more than colleagues, completed work before the deadline, used time well, had creativity or ideas in completing tasks, not delaying work, without depending on others, taking the initiative to complete work, making their performance increase in line with the company's desired goals. This is in line with research conducted by (Yantika et al., 2018).

According to Gulo (2020:18) states that the factors that influence performance are personal factors which include knowledge, skills, abilities, self-confidence, motivation, work ethic, work discipline and commitment possessed by each individual. Leadership factors include enthusiasm, direction and support provided by the team leader. Team factors include the quality of support and enthusiasm provided by teammates, trust in fellow team members. System factors which include work systems, work facilities or infrastructure provided by the organization, organizational processes, and performance culture within the organization and situational factors which include pressure and changes in the external and internal environment.

## **6. Conclusions And Recommendations**

This research found an influence between work environment variables, work discipline and work ethic on employee performance at PT JMPS Lemabang Head Office, Palembang City. A good work environment at PT JMPS, which includes relationships between employees and superiors, facilities, lighting, room size and temperature, has a positive impact on employee performance. The better the work environment, the better the

employee's performance, so that they can fulfill company goals well.

Employee discipline, such as being on time, obeying rules, and being responsible for work, also has a significant effect on employee performance at PT JMPS. This discipline plays an important role in improving overall performance.

Apart from that, employee work ethic, which includes cooperation, enthusiasm for completing tasks, trust and integrity, also influences employee performance in this company. A strong work ethic has a positive impact in achieving optimal work results.

In conclusion, a good work environment, high discipline and a strong work ethic play an important role in improving employee performance at PT JMPS Lemabang Head Office, Palembang City. By paying attention to and improving these aspects, companies can achieve their business goals more effectively and efficiently. The implication of this research for PT Jaya Masawan Putra Sejahtera is that there are practical recommendations that can be implemented to improve employee performance and work atmosphere. First, the importance of providing lunch catering facilities to facilitate social interaction, increase productivity, job satisfaction and employee health. Second, control the temperature of the work environment to suit employee preferences by using digital temperature detection tools and adjusting the temperature again if necessary. Third, there is a need for employee training in both work skills and emotional and spiritual aspects to increase awareness of duties and responsibilities, manage stress, improve customer service, and maintain the environment, discipline and work ethic. Fourth, implement a reward and punishment system to encourage employee performance, by providing rewards for good performing employees and punishing low performing employees. Lastly, the company's role is in facilitating the formation of discipline and a good work ethic through the implementation of fines, training and seminars to improve employee abilities and experience, as well as supporting overall performance. By adopting these recommendations, it is hoped that PT Jaya Masawan Putra Sejahtera can improve its operational effectiveness and better achieve company goals.

## Reference

1. Adela Putri, K., Rialmi, Z., & Suciati, R. (2022). The Influence of Work Environment, Work Discipline, and Work Motivation on the Performance of Police Personnel at the Sawahlunto Resort Police Office. *Ikra-Ith Ekonomika*, 5(2), 116–124.
2. Aqsariyanti, L., Sjahruddin, H., & Razak, N. (2019). The Influence of Work Ethic and Organizational Climate on Employee Performance. *Authors*, 1, 27–36.
3. Arifuddin, M. (2023). *The Influence of the Work Environment, Work Ethics and Work Discipline on Employee Performance in the Protocol and Communication Section of the Banjarmasin City Regional Secretariat Leadership*. 4.
4. Arum, R. S., Rahmawati, E. D., & Suyanto, A. (2023). Work Environment, Work Ethics, and Work Discipline on Employee Performance. *Incandescent Journal*, 1(4), 83–88.
5. Badriati, B. El. (2021). Work Ethic in Islamic and Cultural Perspectives. In *Work Ethic in Islamic and Cultural Perspectives*.
6. Budiyanto, E., & Mochklas, M. (2020). Employee Performance Viewed from Leadership Style Aspects, Organizational Culture and Work Motivation. In *HR Performance Evaluation*.
7. Burhannudin, B., Zainul, M., & Harlie, M. (2019). The Influence of Work Discipline, Work Environment, and Organizational Commitment on Employee Performance: Study at Banjarmasin Islamic Hospital. *Maksipreneur Journal: Management, Cooperatives, and Entrepreneurship*, 8(2), 191. <https://doi.org/10.30588/jmp.v8i2.425>
8. Butarbutar, M., Efendi, Simatupang, S., & Sianturi, M. (2021). The Influence of Work Ethic on Employee Performance at the Sari Asih Nusantara Pematangsiantar Foundation. *Maker: Journal of Management*, 7(1), 116–124. <http://www.maker.ac.id/index.php/maker>
9. Dewi, S. N., & Marpaung, N. N. (2023). The Influence of Work Environment and Work Discipline on Employee Performance at PT. Kiyokuni Indonesia. *PARAMETER*, 8(1), 1–12.
10. Farida, U., & Hartono, S. (2016). Human Resource Management. *Unmuh Ponorogo Press*, 185(1), 26.
11. Firdausyi, A. R., & Kasmari. (2022). The Influence of Work Ethic, Work Discipline and Work Environment on Employee Performance (Case Study at the Semarang Regency Regional Financial Agency Office). *Mirai Journal of Management*, 7(1), 307–318.
12. Firmansyah M.A & Mahardika B.W. (2018). *Introduction to Management*. December, 376.
13. Ginting, D. (2016). Work Ethic: A Guide to Becoming a Smart Employee. *Work Ethic: A Guide to Becoming a Smart Employee*, 165.

15. Grace, E., Manawari, G., & Sudung, S. (2021). The Impact of Work Ethic on PT Employee Performance. *Karya Bhakti Manunggal.Banyanka*, 15(11), 5841–5848.
16. Trouble, S. (2020). *The Influence of Work Motivation, Job Satisfaction and Work Ethic on the Performance of West Nias Regency Youth and Sports Service Employees*. HKBP Nommensen University.
17. Handayani, R., & Oktapiani, S. (2021). The Influence of Discipline and Work Environment on Employee Performance at PT. PLN (Persero) Pasar Minggu Education and Training Center, South Jakarta. *Madani Multidisciplinary Journal*, 1(3), 175–190. <https://doi.org/10.54259/mudima.v1i3.167>
18. Hasyim, & Pasaribu, F. (2021). The Influence of Organizational Climate, Competence and Work Discipline on Employee Performance at the North Labuhan Batu Samsat Office. *Humanities Journal*, 5(1), 153–169.
19. Hidayati, S. K., Perizade, B., & Widiyanti, M. (2019). Effect Of Work Discipline And Work Environment To Performance Of Employees. *International Journal of Scientific and Research Publications (IJSRP)*, 9(12), 391–
20. 398. <https://doi.org/10.29322/ijsrp.9.12.2019.p9643>
21. Huseno, T. (2016). *Employee Performance* (p. 146). Tim MNC Publishing.
22. Imbron, I., & Pamungkas, I. B. (2021). Human Resource Management. *Widina Main Media*, 1–27.
23. Juliati, F. (2021). The Influence Of Organizational Culture, Work Ethos And Work Discipline On Employee Performance. *ACADEMIC Economics & Business Student Journal*, 1(1), 34–39.
24. Julita. (2020). The Influence of Discipline and Work Environment on the Performance of PDAM Tirta Mountala Aceh Besar Employees. *Thesis, FACULTY OF ISLAMIC ECONOMICS AND BUSINESS AR-RANIRY STATE*
25. *ISLAMIC UNIVERSITY BANDA ACEH*, 1–103. <https://repository.ar-raniry.ac.id/id/eprint/15518>
26. Khaeruman, Marnisah, L., Idrus, S., Irawati, L., Farradia, Y., Erwantiningsih, E., Hartatik, Supatmin, Yuliana, Aisyah, N., Natan, N., Widayanto, M. T., & Ismawati. (2021). Improving Human Resource Performance Concepts & Case Studies. In *CV AA Rizky* (1st ed.). CV AA Rizky.
27. Map, M. H., & Baeha, V. M. (2020). The Influence of Work Motivation, Work Ethic and Work Discipline on the Performance of Public Works and Spatial Planning Service Employees in Nias Regency. In *HKBP Nommensen University*.
28. Maryani, D., Irwantp, T., & Effendi, Y. (2022). The Influence of the Work Environment and Work Motivation on Performance at the Communication, Informatics and Statistics Service of Bengkulu Province. *Scientific Journal of Economics and Business*, 11(1), 223–228.
29. Mashuri, Heryanto, H., Heru Purnama, T., & Rayendra, D. (2019). The Effect of Work Environment, Work Discipline, Work Ethics and Work Motivation on Employee Performance (Case Study at General Section of the Regional Secretariat, Sungai Penuh City). *American Journal of Humanities and Social Sciences Research*, 12, 170–178. [www.ajhssr.com](http://www.ajhssr.com)
30. Meilinda, R., Sunarto, A., & Ellesia, N. (2022). Employee Performance Based on Work Ethics and Work Discipline at PT Global Edutek Solusindo in South Tangerang. *Madani Journal: Science, Technology and Humanities*, 5(1), 19–
31. 26. <https://doi.org/10.33753/madani.v5i1.187>
32. Munardi, H. T., Djuhartono, T., & Sodik, N. (2021). The Influence of the Work Environment on Employee Performance at PT National Finance. *Journal Research*, 1(2), 336. <https://doi.org/10.32493/arastirma.v1i2.12371>
33. Nabilla, A., HT, H., & Muzayanah. (2022). *The Influence of Work Ethic on Employee Performance in Employees of the Ministry of Religion of South Sumatra Province*. 5(2), 128–141.
34. Ningrat, & Yudana. (2020). The Contribution of Work Ethic, Work Motivation, Work Discipline and Academic Supervision to the Performance of Elementary School Teachers in GUGUS VII, BERWI DISTRICT. *Indonesian Journal of Educational Administration*, 11(1), 54–64. <https://www.neliti.com/id/publications/78494/konsep-sistem-informasi>
35. Olivia, G., Sari, S. Y., & Fenia, S. Z. (2023). The influence of work discipline, work ethic and organizational commitment on employee performance at PT. Harry Tridharma Padang City. *Digital Business*, 1(1), 29–41.
- Prakoso, S., Wiranta, D., & Lesmana, A. (2020). Work Ethics and Work Discipline in Improving PD Employee Performance. *Nature Various Aromas Sukabumi.Economist Journal*, 6(1), 60–67.
36. Putu, I., Guna, A. A., Ketut, I., Sapta, S., & Rihayana, I. G. (2022). The Influence of Organizational Climate, Work Ability and Work Motivation on Employee Performance at Pt.Adika Jaya Dewata Denpasar. *Values*, 3, 401–417. <https://e-journal.unmas.ac.id/index.php/value/article/view/4906%0Ahttps://e-journal.unmas.ac.id/index.php/value/article/download/4906/3819>
37. Risma, G., & Arwiah, M. Y. (2022). The Influence of Work Discipline and Work Ethic on Employee Performance at the Bandung City Regional Revenue Agency. *ATRABIS: Journal of Business Administration*, 8(1), 30–36.
38. Riwukore, J. R., & Habaora, F. (2022). Training on Preparing Dimensions of Employee Performance in the

- National Unity, Political and Community Protection Agency of the Kupang City Government. *Lumbung Innovation: Journal of Community Service*, 7(3), 341–451. <https://doi.org/10.36312/linov.v7i3.844>
39. Rotto, D. F., Trang, I., & Lumintang, G. G. (2022). Analysis of the Influence of the Work Environment, Work Discipline, and Work Motivation on Employee Performance in the Public Works and Regional Spatial Planning Department of North Sulawesi Province. *Emba*, 10(4), 1181–1192.
  40. Saputra, M. O., Abbas, B., & Sabilalo, M. A. . . (2019). The Influence of Work Discipline and Work Ethic on Employee Performance and Organizational Performance at Bank Sultra. *SIGMA: Journal of ...*, 2(79), 81–91.
  41. Simanjuntak, P. A. (2020). The Influence of Work Ethic, Job Satisfaction, Work Attitude and Work Motivation on Employee Performance at the Medan Polonia Primary Tax Service Office. *Business Journal Master of Management*, 2(1).
  42. Soejarminto, Y., & Hidayat, R. (2022). The Influence of Work Motivation, Work Discipline, and Work Environment on Employee Performance of Pt. Star Korea Industri MM2100 Cikarang. *Ikraith-Ekonomika*, 6(1), 22–32. <https://doi.org/10.37817/ikraith-ekonomika.v6i1.2465>
  43. Sugiarti, E. (2021). The Influence of Training, Work Environment and Career Development on Work Motivation That Has an Impact on Employee Performance at PT. Suryamas Elsindo Primatama In West Jakarta. *International Journal of Artificial Intelligence Research*, 6(1). <https://doi.org/10.29099/ijair.v6i1.304>
  44. Suhardi. (2018). *Introduction to Management and its Applications*. MEDIA STAGE.
  45. Sunarno. (2021). The Influence of the Work Environment and Work Discipline on Employee Performance at the West Bekasi District Office. *PERFORMANCE Journal of Economics and Business*, 3(02), 230–244. <https://doi.org/10.34005/kinerja.v3i02.1554>
  46. Suryadi, S., & Karyono, K. (2022). The influence of job satisfaction, work discipline and work ethic on the performance of PT employees. Keihin Indonesia. *Jesya (Journal of Economics & Sharia Economics)*, 5(1), 85–95. <https://doi.org/10.36778/jesya.v5i1.563>
  47. 95. <https://doi.org/10.36778/jesya.v5i1.563>
  48. Tajudin, T., & Supriadi, T. (2021). The Influence of Work Discipline and Motivation on Employee Performance at PT Suara Bersama, Jakarta. *Journal....*
  49. Tsauri, S. (2013). HRM - Human Resources Management. In *Journal of Modern African Studies* (Vol. 35, Issue 17). W Enny, M. (2019). *Human Resource Management*. <http://eprints.ubhara.ac.id/424/31/Buku-MSDM-2019.pdf>
  50. Yantika, Y., Herlambang, T., & Rozzaid, Y. (2018). The Influence of Work Environment, Work Ethic, and Work Discipline on Employee Performance (Case Study in Bondowoso Regency Government). *Indonesian Journal of Management and Business*, 4(2), 174. <https://doi.org/10.32528/jmbi.v4i2.1760>
  51. Yasdianto, I., Marnisah, L., & Zamzam, F. (2020). The Influence of Work Ethic, Motivation and Organizational Climate on the Performance of the Asset & Office Management Department of Pt Semen Baturaja (Persero) Tbk. *Ekonomika Sharia: Journal of Islamic Banking Thought and Development*, 6(1), 97–116. <https://doi.org/10.36908/ेशa.v6i1.143>
  52. Yustini, T., & Yuliza. (2021). Analysis of Studies during the Covid-19 Pandemic. *Analysis of Studies During the Covid-19 Pandemic*, 2021.

## Author Profile

Eko Wijaya Putra Utama, born in Palembang 09 March 1996, the 3rd of 3 siblings, completed a Bachelor's Degree in Tax Accounting at Musi Charitas Catholic University in 2018 and continued his Masters at Indo Global Mandiri University from 2022 to 2024.

Dr. Muhammad Wadud, S.E., M.Sc., CF., CDM., Cmarcom. CME, the author was born in Sekayu on July 7 1975, the fifth of six siblings. Author: Civil Servant Lecturer (L2dikti Region 2) employed at Indo Global Mandiri University in the Master of Management study program. The author has liked economics, management and business since childhood. The author's educational history starts from high school economics (SMEA/SMK) majoring in finance, then continued with an undergraduate program at the UMP Management Study Program specializing in marketing completed in 1999, continued with a Masters in Economics at UNSRI in the field of regional development planning studies completed in 2003 , and in 2017 continued with the UNSRI management science doctoral program in the field of strategic management, graduating in 2021 and having various competency certifications such as digital certification *marketing*, finance certification, communication certification *marketing* and others. The courses taught are Entrepreneurship 1 and Entrepreneurship 2, Operational Management, Marketing Management, Introduction to Management,

Marketing Research, Marketing Strategy and Strategic Management. The author is also active in various professional organizations such as ISEI, ADRI, IFEST and others. Apart from that, the author is also active in various publications at national and international levels, active in various scientific meetings both offline and *online* (webinar), the author is also a journal editor and reviewer in various journals in the field of management. The author is also active as a speaker and active in community service activities.

*E-mail* Author: wadud@uigm.ac.id