

The Effect of Distribution and Promotion on Customer Satisfaction and the Impact on Customer Loyalty in the Product Nestle Indonesia in Aceh Besar

Khairul Rizki^{1*}, Muhammad Adam², Mukhlis³

Management Department, Universitas Syiah Kuala, Indonesia

Abstract

This research aims to see the Distribution and Promotion effect on Customer Satisfaction and its impact on Customer Loyalty of Nestle Indonesia company in Aceh Besar. The population was all customers of Nestle Indonesia in Aceh Besar Regency. Samples were determined based on Structural Equation Modeling (SEM) analysis using the formula 10 times the number of indicator variables, totaling 18 indicators used, totaling 180 samples. Data were processed using SEM. The results show that Distribution influences Customer Satisfaction, Promotion influences Customer Satisfaction, Distribution influences customer loyalty, Promotion influences Customer Loyalty, Customer Satisfaction influences Customer Loyalty, Customer Satisfaction mediates the Distribution effect on Customer Loyalty, and Customer Satisfaction mediates the Promotion effect on Customer Loyalty. These findings explain the presence of Distribution and Promotion variables which can have an impact on customer loyalty through customer satisfaction. Interestingly, partial mediation plays a role in customer satisfaction, so distribution and promotion can influence customer loyalty both directly and indirectly. This premise can be developed by adding new variables in further research.

Keywords: Distribution, Promotion, Customer Satisfaction, Customer Loyalty

1. Introduction

PT Nestlé Indonesia (Nestle) is a subsidiary of Nestlé SA. Nestlé Indonesia employs around 3,400 employees and operates four factories, namely the Kejayan Factory in East Java to process dairy products such as DANCOW and BEAR BRAND, the Panjang Factory in Lampung to process NESCAFÉ instant coffee, the Cikupa Factory in Banten to produce FOX'S, POLO and CRUNCH confectionery products, and the Karawang Factory in West Java to produce DANCOW, MILO, and CERELAC. Products from Nestlé Indonesia have spread throughout Indonesia, including in Aceh Besar Regency. Marketing of Nestlé's products in Aceh Besar experiences several obstacles in the field, such as a wide distribution reach where the process of distributing goods often experiences delays. Another obstacle lies in sales promotions, where many of Aceh Besar's locations are in remote villages, meaning that people do not receive information about sales promotions. In marketing its products, PT Nestlé Indonesia uses third-party services as distributors. The distributor who distributes products in Aceh Besar Regency is Atjeh Mitra Mandiri (AMM). AMM was founded in 2017 and has more than 5 years of experience in the field of Fast Moving Consumer Goods Distribution in Aceh through good partnership cooperation with many principles. AMM is the best Distribution Partner in Aceh, apart from being supported by guarantees from National Banking. AMM has also long had very good relationships with more than 1,000 Outlets in Aceh, including Supermarket, Supermarkets, Whosaler / Wholesale, Minimarket and Kiosk channels, and Medical Channels such as

Pharmacies, Doctors' and Midwives' Practices, Hospitals, and Horeca Channel. (Hotels, Restaurants and Cafes). The following is the sales trend for PT Nestlé Indonesia products in Aceh Besar Regency in 2023.

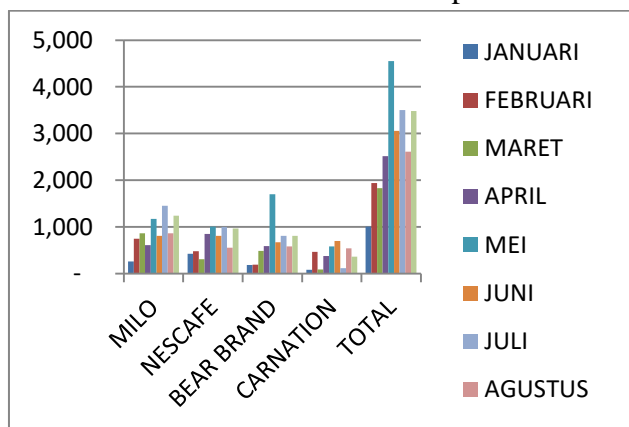

Source: PT Nestlé Indonesia

Figure 1 Sales Trend in 2023

Figure 1 shows that the sales performance of PT Nestlé Indonesia products in Aceh Besar Regency fluctuated during the period from January to September 2023. The highest sales were in May 2023, while the lowest were in January 2023. This unstable sales performance is the impact of the lack of customer loyalty in using Nestle products. Customers are inconsistent in consuming Nestle products, which means that Nestle products are not the main product used by consumers. Based on the results of the initial survey, it is known that respondents' perceptions regarding loyalty are good with an average value of 3.89. However, there are still unfavorable indicators where there are respondents who will switch to other products, and respondents also still have little confidence in Nestle Indonesia products.

Many factors influence customer loyalty, one of which is customer satisfaction. The research by (Wardhana, Hidayah, & Wahyuni, 2017) found that customer satisfaction has a positive and significant influence on loyalty. The initial survey shows the respondents' perception of satisfaction is good with an average value of 3.75. However, there are still unfavorable indicators where there are respondents who feel they do not need to advance Nestle Indonesia products. One of the factors that influences customer loyalty and satisfaction is distribution. Distribution can determine whether the products sold by the company can be distributed to consumers. Consumers will be reluctant to purchase products if the products offered are difficult for consumers to obtain. If the company can provide products at the right time and place, consumers can be satisfied, thereby creating brand loyalty. The research results of (Dipayanti & Hernayadi, 2022) found that distribution affected customer loyalty. The initial survey reveals respondents' perceptions regarding distribution are good with an average value of 3.72. However, there are still unfavorable indicators, where there are respondents who feel that Nestle products sometimes experience shortages in the market.

The next factor is promotion. Good promotion is one way for companies to introduce their products so that their customers can continue to remember them because, with marketing developments that are currently very competitive, many products show the advantages and disadvantages of their products in the market. In this way, customer loyalty will increase. The research results of (Dipayanti & Hernayadi, 2022) found that promotions affect customer loyalty. The initial survey found respondents' perceptions regarding Promotion are good with an average value of 3.63. However, there are still unfavorable indicators where there are respondents who feel that Nestle products have not been promoted for a long time

2. Literature

Customer loyalty

(Tjiptono, 2017) defines Loyalty as something that arises without coercion but arises by itself. (Sangadji & Sopiah, 2014) stated Customer loyalty is when people keep buying things from the same company over and

over again. Customers buying from the company regularly can help the company in the long run.. (Tjiptono, 2014) said Customer loyalty is when a customer likes a brand, store, or supplier and keeps buying from them over and over again because they are happy with the products or services. (Hidayat, 2009) reveals Customer loyalty is when a customer likes a brand, store, or supplier and keeps buying from them over and over again because they are happy with the products or services, with Indicators:

1. *Trust* is a response to customer trust in the market.
2. *Emotional commitments* are the customer's psychological to the market
3. *Switching costs* the customer's response when changes occur
4. *Word of mouth* is publicity by customers towards the market.
5. *Cooperation* is customer behavior that cooperates with the market.

Customer satisfaction

According to (Tjiptono, 2017), customer satisfaction is a passionate reaction to encounters related to certain products or services purchased, retail outlets, or indeed behavioral designs (such as shopping behavior and buyer behavior), as well as the advertising as an entire. Passionate reactions are activated by a cognitive departure handle that compares discernments (or convictions) of certain objects, activities, or conditions with the individual's values (or needs, needs, and wants). Meanwhile, according to (Daryanto & Setyobudi, 2014), customer satisfaction is an emotional assessment of the customer after the customer uses a product where the expectations and needs of the customer who uses it are met. (Kotler & Keller, 2018) said satisfaction indicators are as follows:

1. *Satisfaction*: Stay with the company as long as expectations are met
2. *Repeat purchase*: Return to the company to buy again
3. *Word of Mouth/Buzz*: Promotes its reputation to let others know about the company.
4. *Evangelism*: Convince other people to buy the company's products
5. *Ownership*: Feeling responsible for the company's continued success

Distribution

Distribution is an activity that must be carried out by entrepreneurs to distribute, distribute, send, and convey the goods they market to customers (Gitosudarmo, 2014). In distributing products, companies need distributors, whether distributors owned by the company or from outside the company so that the products sold can be consumed by customers/product users. (Kotler & Armstrong, 2018) stated distribution is a company activity that makes products available for consumption by consumers. A company's channel decisions will directly influence all other marketing decisions. The indicators (Gitosudarmo, 2014) include:

1. Product availability
2. Distribution reach
3. Level of convenience

Promotion

(Daryanto & Setyobudi, 2014) explained Promotion is when someone tries to convince others to buy something through communication or persuasion. It's a way to make people want to buy things from a company or person. Promotion is a way to tell people about products and persuade them to buy. (Oentoro, 2012) stated Promotion is when companies try to tell and persuade people to buy or use their products. Indicators according to (Alma, 2013) say that:

1. Advertising/Advertising
2. Individual sales/Personal Selling
3. Sales promotion/Sales
4. Public Relations

- 5. Direct marketing
- 6. Direct marketing is a system

3. Method

In this research, the intended population was all customers of Nestle Indonesia in Aceh Besar Regency. Determining the number of samples for Structural Equation Modeling (SEM) analysis uses the formula 10 times the number of indicators, totaling 18 indicators used (Ferdinand, 2014) so it is people as 180 samples. The sampling carried out in this research used random sampling among Nestle Indonesia customers in Aceh Besar Regency. Data were processed using the SEM through AMOS.

4. Result and Discussion

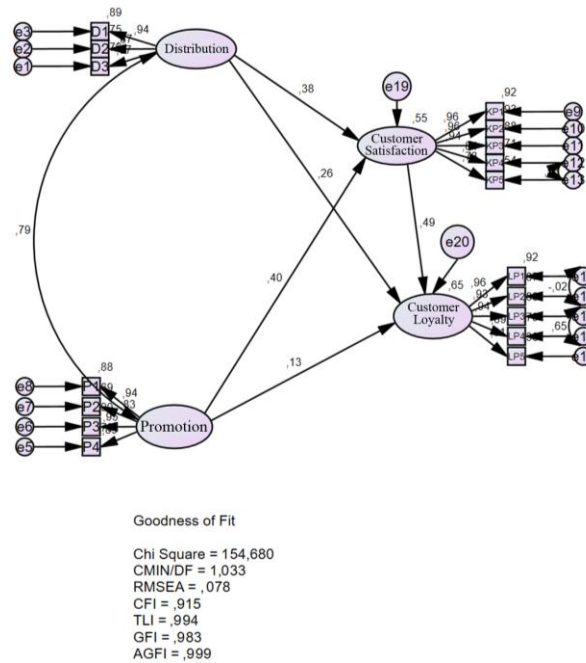

Figure. 2. Structural Model

Hypothesis test

This research hypothesis testing was carried out based on the *Critical Ratio* (CR) in Table 2 below.

Table 1. Regression

| | Influence | Estimate | S.E | CR | P | R-Square |
|-----------------------|----------------------------|----------|-------|-------|-------|----------|
| Customer satisfaction | <--- Distribution | 0.384 | 0.128 | 3,914 | 0,000 | 0.551 |
| Customer satisfaction | <--- Promotion | 0.400 | 0.123 | 4,118 | 0,000 | |
| Customer loyalty | <--- Distribution | 0.261 | 0.101 | 2,806 | 0.005 | 0.649 |
| Customer loyalty | <--- Promotion | 0.232 | 0.096 | 2,451 | 0.035 | |
| Customer loyalty | <--- Customer satisfaction | 0.490 | 0.063 | 6,489 | 0,000 | |

Source: Processed Primary Data, (2023)

Distribution on Satisfaction

The distribution influence testing on customer satisfaction obtained CR 3.914 with p 0.000, concluding that Distribution affects significantly Customer Satisfaction. The Distribution effect size on Customer Satisfaction is 0.384 or 38.4%, showing that improving 1 unit distribution will increase 0.384 units of customer satisfaction.

Promotion on Satisfaction

The promotions influence testing on customer satisfaction obtained CR 4.118 with p 0.000, explaining that promotions affect significantly customer satisfaction. The Promotion effect size on Customer Satisfaction is 0.400 or 40.0%, showing that the 1 unit higher the promotion level, the 0.4 units increase in customer satisfaction.

Distribution on Loyalty

The distribution influence testing on customer loyalty obtained CR 2.806 with p 0.005, explaining that distribution affects significantly customer loyalty. The Distribution effect size on Customer Satisfaction is 0.261 or 26.1%, showing that the 1 unit higher the distribution level, the 0.261 units increase in customer loyalty.

Promotion on Customer Loyalty

The promotion influence testing on customer loyalty was obtained CR 2.451 with p 0.035, explaining that Promotion affects significantly Customer Loyalty. The Promotion effect size on Customer Loyalty is 0.232 or 23.2%, showing that the 1 unit higher promotion will increase 0.23 units of customer loyalty.

Satisfaction on Loyalty

The Customer Satisfaction influence testing on Customer Loyalty obtained CR 6.489 with p 0.000, explaining that Customer Satisfaction influences significantly Customer Loyalty. The Customer Satisfaction effect size on Customer Loyalty is 0.490 or 49.0%, showing that the 1 unit higher customer satisfaction will increase 0.49 units of customer loyalty.

Distribution towards Loyalty through Satisfaction

Sobel test produces the result 3.342 with p 0.000, explaining Customer Satisfaction acts as a mediator between Distribution and Customer Loyalty. So, because Customer Satisfaction significantly affected and significantly acted as a mediator, Distribution significantly affected Customer Loyalty, the Customer Satisfaction role in mediating Distribution and Customer Loyalty is partially mediating. Partial mediation means that the Distribution effect on Customer Loyalty can happen both directly or through Customer Satisfaction.

Table 3. Sobel Distribution Test Results Towards Loyalty Through Satisfaction

| Input: | | Test statistic: | Std. Error: | p-value: |
|----------------|-------|--------------------------|-------------|------------|
| a | 0.500 | Sobel test: 3.34270042 | 0.06087892 | 0.00082967 |
| b | 0.407 | Aroian test: 3.31375598 | 0.06141068 | 0.00092052 |
| s _a | 0.128 | Goodman test: 3.37241681 | 0.06034248 | 0.00074512 |
| s _b | 0.063 | Reset all | Calculate | |

Promotion on Loyalty through Satisfaction

Sobel test produces the result 3.474 with p 0.000. Thus, Customer Satisfaction acts as a mediator between Promotion and Customer Loyalty. So, because Customer Satisfaction significantly affected and significantly acted as a mediator, Promotion significantly affected Customer Loyalty, so the Customer Satisfaction role in mediating Promotion and Customer Loyalty is partially mediating. Partial mediation means that the Promotion effect on Customer Loyalty can happen both directly or through Customer Satisfaction.

Table 4. Promotion Sobel Test Results Towards Loyalty Through Satisfaction

| Input: | | Test statistic: | Std. Error: | p-value: |
|----------------|-------|--------------------------|-------------|------------|
| a | 0.507 | Sobel test: 3.47488806 | 0.05938292 | 0.00051107 |
| b | 0.407 | Aroian test: 3.44567511 | 0.05988638 | 0.00056963 |
| s _a | 0.123 | Goodman test: 3.50485685 | 0.05887516 | 0.00045685 |
| s _b | 0.063 | Reset all | Calculate | |

5. Conclusion

Based on the results the following are the conclusions

- 1) Distribution influences Customer Satisfaction at Nestle in Aceh Besar.
- 2) Promotions influence Customer Satisfaction at Nestle in Aceh Besar.
- 3) Distribution influences customer loyalty at Nestle in Aceh Besar.
- 4) Promotions influence Customer Loyalty at Nestle in Aceh Besar.
- 5) Customer Satisfaction influences Customer Loyalty at Nestle in Aceh Besar.
- 6) Customer Satisfaction partially mediates the influence of Distribution on Customer Loyalty at Nestle in Aceh Besar.
- 7) Customer Satisfaction partially mediates the effect of Promotion on Customer Loyalty at Nestle in Aceh Besar.

These findings explain the presence of Distribution and Promotion variables which can have an impact on customer loyalty through customer satisfaction. Interestingly, partial mediation plays a role in customer satisfaction, so distribution and promotion can influence customer loyalty both directly and indirectly. This premise can be developed by adding new variables in further research. From the survey data, several recommendations were produced for the subject of this research, namely:

- 1) For the Distribution variable, the company can expand the sales coverage area so that the product is available in many stores close to where the customer is located.
- 2) For the Promotion variable, companies can try to make promotions more often through social media with interesting content so that customers feel interested in seeing the advertisements that are displayed.
- 3) For the Customer Satisfaction variable, companies can increase engagement with customers where the company must create every product that customers need. In this way, a bond will be established between the company and its customers.
- 4) To increase customer loyalty, companies can increase customer satisfaction because satisfaction has the greatest influence on loyalty.

References

1. Alma, B. (2013). *Manajemen Pemasaran dan Pemasaran Jasa* (Revisi). Bandung: Alfabeta.
2. Daryanto, & Setyobudi, I. (2014). *Konsumen dan pelayanan prima*. Yogyakarta: Gava Media.
3. Dipayanti, K., & Hernayadi, H. (2022). Pengaruh Promosi dan Saluran Distribusi terhadap Loyalitas Pelanggan Produk Nellco Special OBH di PT. Lenko Surya Perkasa Cabang Ciracas. *Jurnal Pemasaran Kompetitif*, 5(2), 180–193. <https://doi.org/http://dx.doi.org/10.32493/jpkpk.v5i2.15614>
4. Ferdinand, A. (2014). *Metode Penelitian Manajemen* (Edisi 5). Semarang: Universitas Diponegoro.
5. Gitosudarmo, I. (2014). *Prinsip dasar manajemen*. Yogyakarta: BPFE.
6. Hidayat, R. (2009). Pengaruh Kualitas Layanan, Kualitas Produk dan Nilai Nasabah Terhadap Kepuasan dan Loyalitas Nasabah Bank Mandiri. *Journal of Management and Entrepreneurship*, 11(1), 59–72. <https://doi.org/https://doi.org/10.9744/jmk.11.1.pp.%2059-72>
7. Kotler, P., & Armstrong, G. (2018). *Principles of Marketing* (17th ed.). Pearson Education.

8. Kotler, P., & Keller, K. L. (2018). *Marketing Management, Global Edition* (15th edisi). Harlow, United Kingdom: Pearson.
9. Oentoro, D. (2012). *Manajemen Pemasaran Modern*. Yogyakarta: LaksBang PRESSindo.
10. Sangadji, E. M., & Sopiah. (2014). *Prilaku Konsumen: Pendekatan Praktis*. Jakarta: Andi Offset.
11. Tjiptono, F. (2014). *Pemasaran Jasa : Prinsip, Penerapan, Penelitian*. Yogyakarta: Andi Offset.
12. Tjiptono, F. (2017). *Strategi pemasaran* (4th ed.). Jakarta: Andi.
13. Wardhana, A. A., Hidayah, S., & Wahyuni, S. (2017). Analisis Kinerja Layanan dan Kepuasan Pelanggan terhadap Loyalitas Nasabah Tabungan. *Jurnal Manajemen*, 9(1), 1–7. <https://doi.org/http://dx.doi.org/10.29264/jmmn.v9i1.2390>