

# Modified Fuzzy method for Vertical Handoff in Heterogeneous Networks

<sup>1</sup>Harvinder Gill, <sup>2</sup>Silki Baghla

<sup>1</sup>Research Scholar, ECE Department, JCDM College of Engineering, Sirsa

<sup>2</sup>Asstt. Professor, ECE Department, JCDM College of Engineering, Sirsa

**Abstract-**There are various types of networks in wireless technologies, having different parameters and their specifications and thus having different QoS (Quality of Service). So for moving the MS from one network to another network vertical handoff is required. In this paper we designed the simulation model having seven parameters for vertical handoff between WWAN and cellular network with the help of Fuzzy Logic Tool Box, which is also named as FQDA (Fuzzy Logic Quantitative Decision Algorithm) and Simulink of MATLAB platform. The results show the improved performance and reduced complexity. In this work only 81 rules have been used as compared to 2187 rules needed for 7 attributes. This modified fuzzy method also result in lesser number of handoffs as compared to traditional method.

**Keywords-** QoS, FQDA, WWAN

## 1. INTRODUCTION

Wireless technology provides number of wireless networks like WLAN, WWAN, Wi-Max etc. Each network has its own specifications and parameters. The handoff is required for moving the MS from one network to another to maintain connectivity. When a MS moves between same network e. g WLAN to WLAN, the handoff is known as Horizontal Handoff (HHO). On the other hand when MS moves between two different or heterogeneous networks e.g WLAN to WWAN, handoff is known as Vertical handoff (VHO). Vertical handoff is used to maintain the QoS. The handoff process contains three steps: First step is Fuzzification in which the input value is fuzzified in the form of membership functions. The second step is to design if-then rules requires for implement the vertical handoff. The third step is Defuzzification in which the membership functions are defuzzified in output values.

In this paper, vertical handoff is done between the two heterogeneous networks that are WWAN and cellular network with the help of FIS (Fuzzy Interference System) and simulation models. The vertical handoff mechanism between WWAN and cellular network is shown in Fig. 1.

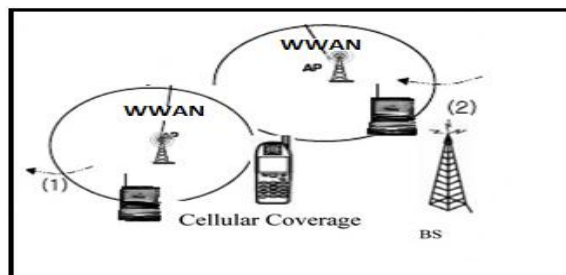

Fig.1 Vertical handoff between WWAN and cellular network

The vertical handoff depends upon number of parameters. In this paper seven parameters are considered for vertical handoffs which are bandwidth, RSS, security, delay, jitter, velocity and cost. By using FQDA and simulink model the number of parameters increase with less number of rules which results in better performance with less complexity. The rest of the paper is organized as follows

Related work, Proposed scheme, simulation and results are explained below.

## 2. RELATED WORK

A lot of work has been done from recent years. Various types of technics and algorithms have been introduced for vertical handoff in order to improve the QoS. Wireless Systems (NGWS) integrate different wireless systems, each of which is optimized for some specific services to the mobile users. In [1] proposed a method to enhance the handoff performance of mobile IP in wireless IP networks by reducing the false

handoff probability in the NGWS handoff management protocol. Based on the information of false handoff probability effect on mobile speed and handoff signal delayed authors in [2] proposed the performance of vertical handover (VHO) algorithms for seamless mobility between WiFi and UMTS networks. By focused on a no-coupling scenario, between the involved players (users and network operators), form of corporation is introduced. In “hostile” scenario, the VHO operations are completely operated by the mobile terminal (MT). The authors first proposed a low-complexity Received Signal Strength Indicator (RSSI)-based algorithm and, then, an improved hybrid RSSI. Based on the implementation of RSSI-based VHO Algorithm an effective output has been increased at the MTs. In [3] authors proposed classical and existing fuzzy approaches adopted for vertical handoff to ensure seamless mobility across overlaid heterogeneous networks. A neuro-fuzzy multi-parameter-based vertical handoff decision algorithm (VHDA) has been proposed. The proposed VHDA considers six parameters and data base rule set. The average number of vertical handoffs was reduced by 13.3 and 29.8% for the existing fuzzy technique and the classical technique, respectively. The ping-pong effect had been reduced by 15.9%, the end-point service availability (ESA) and throughput was increased by 16.57 and 5.97%, in order to improve QoS. A QoS-aware fuzzy rule-based vertical handoff mechanism was proposed in [4] that make a multi-criteria-based decision, in order to improve the requirements of different applications in a heterogeneous networking environment. The QoS parameters considered was available bandwidth, end-to-end delay, jitter, and bit error rate. A new model had been proposed using a non-birth–death Markov chain, in which the states correspond to the available networks. The proposed algorithm had better performance for different traffic classes. The vertical handover decision has been considered an NP-Hard problem. For that reason, [5] has to provide a new approach for the vertical handoff algorithms in order to choose the most appropriate algorithm which should be used to select the best access network. In [6] provided a seamless handoff by selecting the appropriate network in order to be always best connected for various applications, the network selection has been done to choose the most suitable network for mobile user. A handoff decision scheme was proposed that will help to choose the correct network and fuzzy logic is applied to deal with the imprecise information of some criteria and user preference. Due to traffic offloading the decisions for vertical handovers in heterogeneous wireless networks the QoS of the mobile users is very important issue, especially when they are using real-time services. In [7] proposed vertical handover decision algorithm from WiMAX to WLAN networks based on the user’s speed and session’s priority (non-real-time or real-time service) of the mobile nodes. The IEEE 802.21 has been used as a standard layout for implementing the algorithm. The implementation of proposed S handover algorithm avoids unnecessary vertical handover from WiMAX to WLAN in scenarios with various traffic types and speeds of the mobile nodes. Thus the proposed algorithm improved the vertical handover latency, packet loss and average throughput of the mobile users. In [8] authors presented a novel multi-criteria VHO algorithm, which chooses the target NAT based on

several factors such as user preferences, system parameters, and traffic- types with varying Quality of Service (QoS) requirements. The proposed algorithm included two modules i.e., VHO Necessity Estimation (VHONE) module and target NAT selection module, are designed. Both modules utilize several “weighted” users’ and system’s parameters. The weighting system was designed based on the concept of fuzzy linguistic variables in order to improve the performance of the proposed algorithm. The ultimate goal [8] was to provide global connectivity with efficient ubiquitous computing to these MSs based on the Always Best Connected (ABC) principle. For intelligent and efficient Vertical Handoffs (VHOs) between wireless technologies in a heterogeneous environment ,the design and implementation of a fuzzy multicriteria based Vertical Handoff Necessity Estimation (VHONE) scheme was proposed that determines the proper time for VHO, while considering the continuity and quality of the currently utilized service, and the end-users’ satisfaction. In [9] author proposed a novel vertical handover decision mechanism namely FUZZY-technique for order preference by similarity to ideal solution (FUZZY-TOP), obtained by combining a fuzzy rule-based mechanism with the technique for order preference by similarity to ideal solution approach. Markov chain modal had been used for simulation that compared with existing vertical handover decision algorithms. The proposed FUZZY-TOP decision algorithm was performed better for different traffic classes. In [10] proposed a QoS aware fuzzy rule based vertical handoff mechanism fuzzy logic quantitative decision algorithm (FQDA) has been used as an handoff decision criteria to choose which network to handover among different available access networks. The QoS parameters considered was available bandwidth, end-to-end delay, jitter, and bit error rate (BER). As compared to other vertical handoff algorithms, the proposed algorithm has perform better and give better performance for different traffic classes. In [11] intelligent decision algorithm was proposed that detects new network which offers best connectivity than current network and does authentication and mobile IP registration. It reduced the packet loss to ensure high quality of service. Forwarded data packets to appropriate attachment point to maximize battery lifetime with this algorithm , also maintain load balancing. The proposed algorithm efficiently used the network resources by switching between 3G and Wi-Fi under the different RF environmental conditions with minimal service cost to the users. The proposed intelligent decision algorithm reduced the call dropping rate (<0.006) and call blocking probability (<0.00607) as well as unnecessary handover in heterogeneous networks.

### 3. PROPOSED SCHEME

In this paper Fuzzy tool box and simulink has been used to perform simulation . The whole process can be explain briefly as:

#### 3.1 FQDA (Fuzzy Logic Quantative Decision Algorithm)

It is a algorithm used widely in vertical handoff decision because of its simplicity.FIS (Fuzzy logic Interference System

is a part of FQDA. The FIS contains number of functional blocks that are explained as:

### A . Fuzzifier

Input values are convert in the form of membership functions with the help of fuzzifier. The range for these membership functions are also specify with fuzzifier.

### B . Fuzzy rule database

It defines the set of if-then rules that has been useful l in decision making criteria for handoff. Number of rules are depends upon the number of parameters used and set of membership function. Rules can be calculated with the expression or formula that is:

$$[x]^m$$

Where x= number of sets and m= number of parameters.

i.e number of sets used are three and number of parameters are four, then the total number of rules are

$$[3]^4 =81$$

### c. Defuzzifier

This block converts the membership value into the single output value.

There are two types of FIS

- a) Mamdani FIS
- b) Sugeno FIS

In this paper sugeno type FIS is used because it gives better performance than mamdani FIS.

The block diagram of basic FQDA can be shown in fig 2.

### 3.2 Input Parameters

In this paper seven parameters has been proposed. Some of parameters are depends upon MT and some are depends upon the network conditions. Seven parameters are bandwidth, RSS, security, delay, jitter, velocity and cost. Threshold values for each parameter can be explained in table 1.

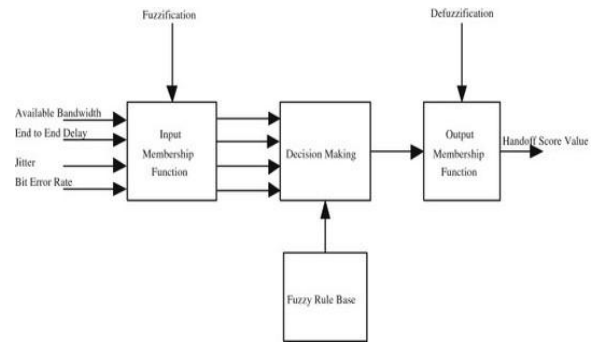

Fig. 2 FIS ( Fuzzy Interference System).

### 3.3 Number of Rules

According to expression used in FIS the number of rules for seven attributes can be calculated as

$$[3]^7 =2187$$

Here 3 is the number of membership function that is low, medium and high. The membership functions for inputs and output are shown in fig. 3.

Parameters	Values
Bandwidth	0 to 56
RSS	-72 to 72'
Security	0 to 70
Delay	25 to 50
Jitter	5 to 10
Velocity	0 to 54
Cost	0 to 60

Table 1 Attributes list along with values.

Range for output function is from 0 to 1. The output membership functions in sugeno FIS are either linear or constant.

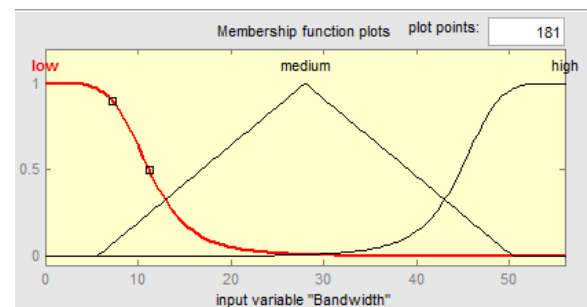

Fig. 3(a) Membership function for bandwidth.

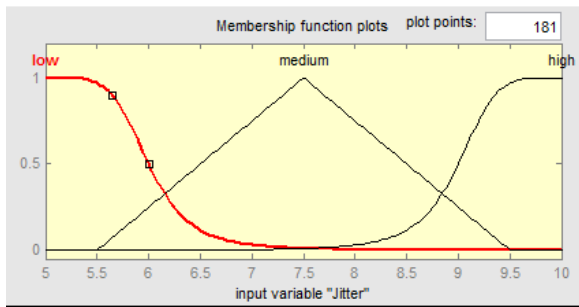

Fig. 3(b) Membership function for jitter.

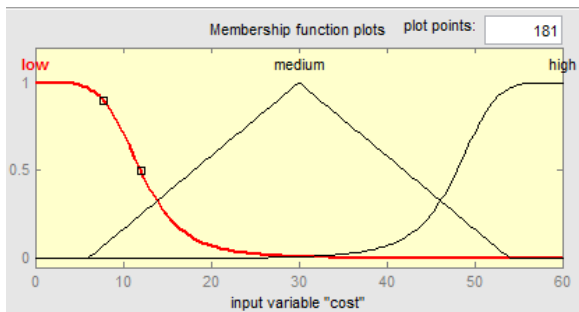

Fig. 3(c) Membership function for cost.

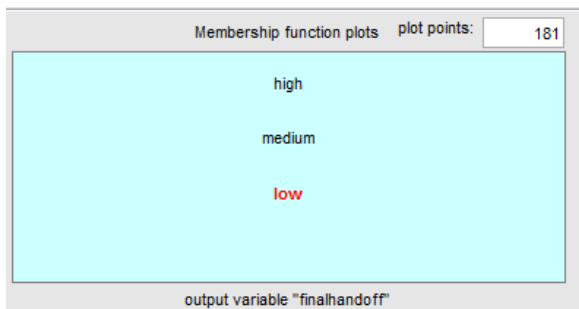

Fig. 3(d) Membership function for output.

#### 4. RESULTS AND SIMULATION

The vertical handoff decision between WWAN and cellular network can be carried out with simulation model. In this paper three models are proposed having three, six and seven parameters respectively. The simulation model contains number of blocks that are explained as:

- Input: This block contain number of inputs. In this paper seven parameters are taken as an seven inputs.
- Fuzzy controller: The function of this block is to design if-then rules. Design is done in with the help of fuzzy tool in FIS.
- Scope: The output will be display with the help of scope either floating scope or non floating scope.

Simulation model having seven parameters or inputs can be shown in fig. 4

Here with the help of simulation model instead of 2187 rules, 81 rules are sufficient for seven parameters.

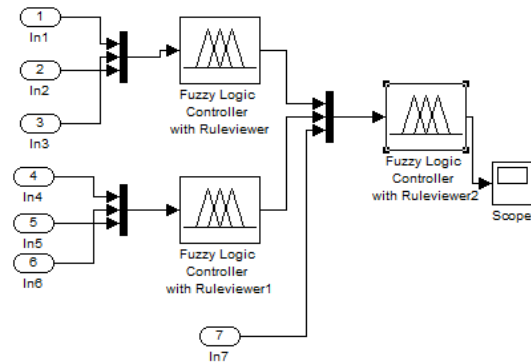

Fig. 4 Model having seven parameters.

On the basis of seven parameters number of rules are defined and decision algorithm is performed with the help of fuzzy tool and simulation model. Some of the rules are specifiers in table 2.

Range of output is from 0 to 1, vertical handoff between WWAN and cellular network is based on the range of output. Result obtained show that:

- If the handoff factor or output is less than 0.45, handoff is done or we can say that MS is move from WWAN to cellular network, if the current network is WWAN.
- If the output is lies between 0.45 to 0.7, there is no handoff. MS remains in the same network.
- If the output is greater than 0.7, the MS moves from cellular network to WWAN. Thus the handover is performed.

	IF		THEN
Bandwidth	RSS	Security	Handoff Decision
Low	High	High	High
High	Medium	Low	Low
High	Medium	Medium	Medium
Medium	High	Medium	Medium

Table 2. If- then rules for vertical handoff.

The output of FIS for sugeno type is shown in Fig.5 for seven parameters. Also the output in the form of graph is shown in fig. 6

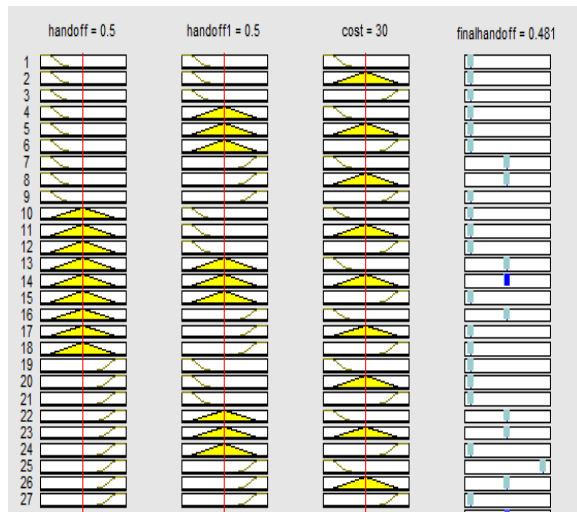

Fig. 5 sugeno based fuzzy inference system output.

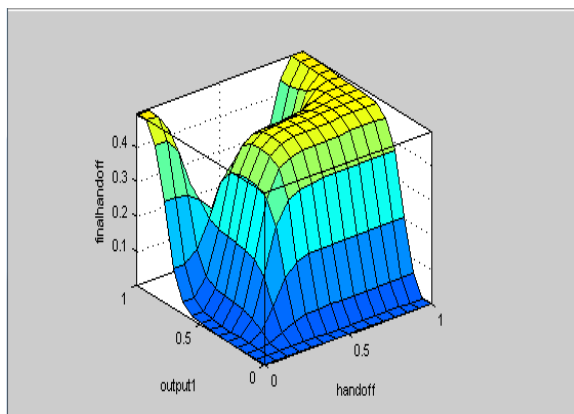

Fig. 6 output graph for vertical handoff.

## 5. CONCLUSION

Proposed models resulted in simulation with large number of attributes with lesser number of fuzzy rules. In this work only 81 rules have been used as compared to 2187 rules needed for seven attributes. Large number of attributes improves the handover decision in heterogeneous networks. In this paper the handoff is performed between WWAN and cellular network. This modified fuzzy method also resulted in lesser number of handoffs as compared to traditional methods.

## REFERENCES

[1] Debabrata Sarddar<sup>1</sup>, Tapas Jana<sup>2</sup>, Souvik Kumar Saha<sup>1</sup>, Joydeep Banerjee<sup>1</sup>, Utpal Biswas<sup>3</sup>, M.K. Naskar<sup>1</sup>, "Minimization of Handoff Failure Probability for Next-Generation Wireless Systems," International Journal of Next-Generation Networks (IJNGN) Vol.2, No.2, June 2010 10.5121/ijngn.2010.2204 36.

[2] Stefano Busanelli, Marco Martal`o, Gianluigi Ferrari, and Giovanni Spigoni, "Vertical Handover between WiFi and UMTS Networks: Experimental Performance Analysis," International Journal of Energy, Information and Communications Vol. 2, Issue 1, February 2011

[3] A.Singhrova,N. Prakash, "Vertical handoff decision algorithm for improved quality of service in heterogeneous wireless networks," IET Commun., 2012, Vol. 6, Issue. 2.

[4] Kantubukta Vasu, Sumit Maheshwari,Sudipta Mahapatra and Cheruvu Siva Kumar, "QoS-aware fuzzy rule-based vertical handoff decision algorithm incorporating a new evaluation model for wireless heterogeneous Networks," EURASIP Journal on Wireless Communications and Networking 2012.

[5] Mohamed Lahby,Leghris cherkaoui and Abdellah Adib, "An Enhanced Evaluation Model For Vertical Handover Algorithm In Heterogeneous Networks," IJCSI International Journal of Computer Science Issues, Vol. 9, Issue 3, No 2, May 2012.

[6] Manoj Sharma, Dr. R.K.Khola, "FUZZY LOGIC BASED HANDOVER DECISION SYSTEM," International Journal of Ad hoc, Sensor & Ubiquitous Computing (IJASUC) Vol.3, No.4, August 2012.

[7] Kire Jakimoski<sup>1</sup> and Toni Janevski<sup>2</sup>, "Vertical Handover Decision Algorithm from WiMAX to WLAN based on the Mobile Node's Speed and the Session's Priority," International Journal of Advanced Science and Technology Vol. 49, December, 2012

[8] Faisal Kaleem, Abolfazl Mehbodniya,Arif Islam,Kang K.Yen, Fumiyuki Adachi, "Dynamic Target Wireless Network Selection Technique Using Fuzzy Linguistic Variables," IEEE January 2013.

[9] Faisal Kaleem, Abolfazl Mehbodniya, Kang K. Yen, and Fumiyuki Adachi, "A Fuzzy Preprocessing Module for Optimizing the Access Network Selection in Wireless Networks," Hindawi Publishing Corporation Advances in Fuzzy Systems Volume 2013.

[10] Vasu Kantubukta, Sumit Maheshwari, Sudipta Mahapatra, Cheruvu Siva Kumar, "Energy and QoS aware FUZZY-technique for order preference by similarity to ideal solution based vertical handover decision algorithm for heterogeneous wireless networks," IET Netw., 2013, Vol. 2, Issue. 3.

[11] M.Sazeeda Kausar,Dhanraj Cheelu, "Context Aware Fuzzy Rule Based Vertical Handoff Decision Strategies for Heterogeneous Wireless Networks," International Journal Of Engineering And Science Vol.3, Issue 7 (August 2013).

